

Product overview

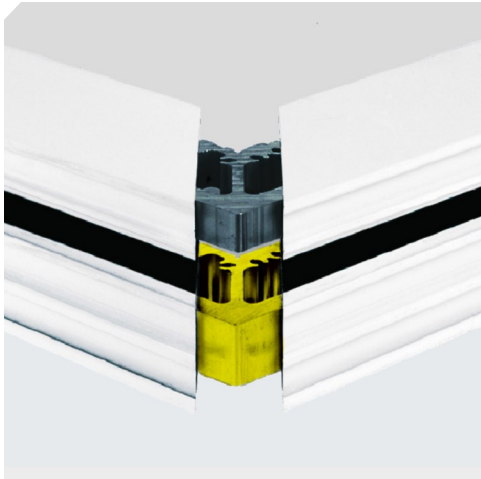
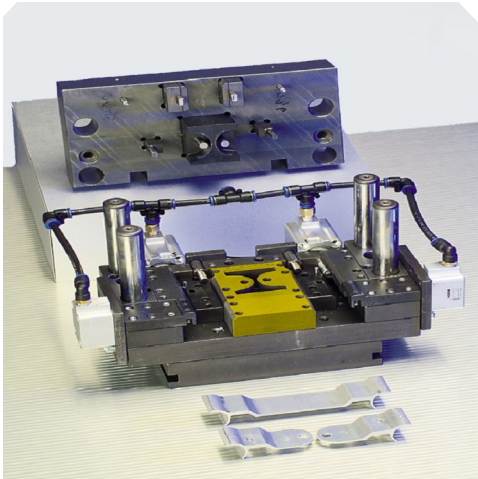
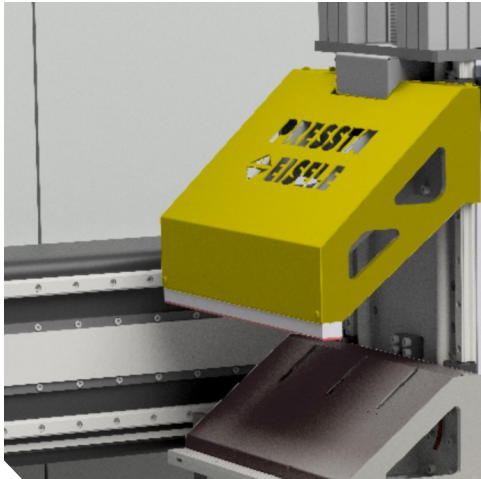
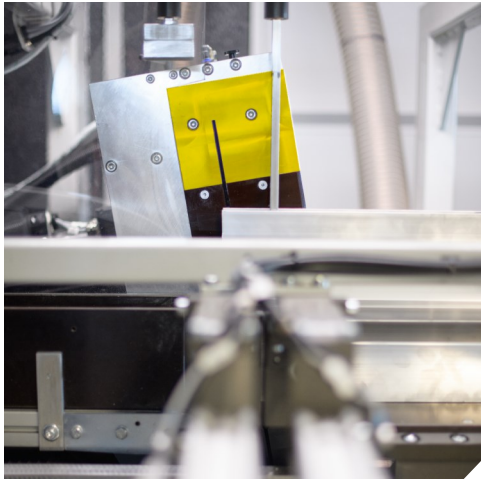

WELCOME TO THE WORLD OF PRODUCTIVITY

PRESSTA EISELE - that's us:

For over 30 years we, Pressta-Eisele GmbH with headquarters in Bullay, have been one of the world's leading suppliers of machines, devices and punching tools for aluminum processing.

Our highly trained employees - thanks to our subsidiaries there are now more than 150 - have a wealth of experience that they use anytime and anywhere for optimal problem solutions.

We consider these solutions to be our most important task and help you to optimize your work processes all around by means of commissioning, professional advice, customer service and software training.

We supply our classic customers in the field of aluminum window and facade construction with reliable, long-lasting machines that are highly economical. As the birthplace of the aluminum corner connection, we demonstrate special competence in this area.

The core of our range of services are our high-performance automatic saws and sawing systems. We offer you individual solutions tailored to your requirements. Thanks to a high level of know-how as well as the most modern construction and manufacturing equipment, we guarantee quality that is second to none.

Our sawing technology is used wherever there are great demands on the saw cut. Our customers include aluminum profile, furniture and aircraft manufacturers, leading pneumatics manufacturers as well as the automotive and electrical industries.

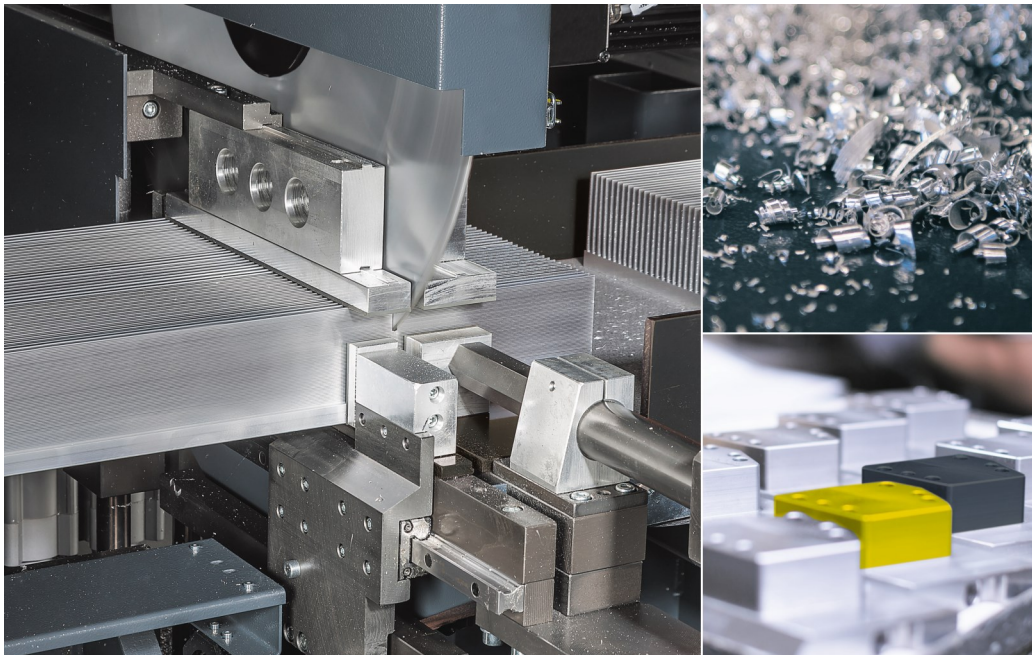

Product overview

Circular saws	from page	5
Roller conveyors & measuring systems	from page	14
Notching saws	from page	17
End milling machines	from page	19
Punching machines	from page	20
Corner crimping units	from page	22
Combination saws	from page	25
Automatic saws	from page	29
Loading magazines	from page	34
Chip extractors	from page	36
Sawing lines	from page	38
Special purpose machines	from page	42
Overview cutting solutions	from page	48

Please note that all machine pictures shown in this catalogue are for explanation / display purposes only and may show accessories, which are only available as options.

SAWING AND PROCESSING OF CONSTRUCTION PROFILES

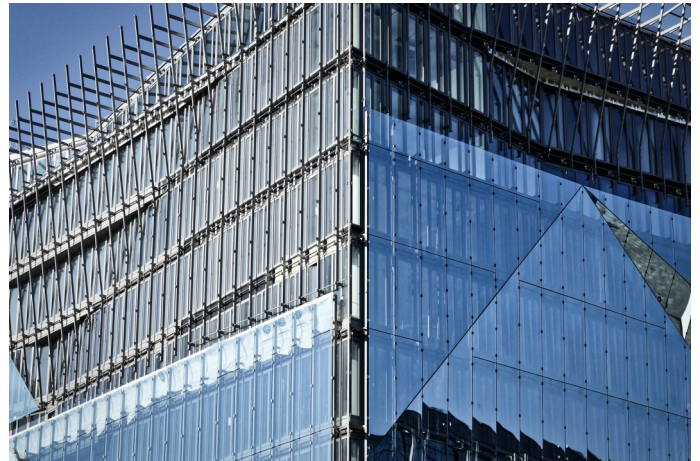

CIRCULAR SAWS

Mitre saws



Table saw **TS 350 (M)**

- for aluminum and plastic profiles
- manual handling, saw cut from below
- drive 1.5KW, 400V / 50Hz
- swiveling material cross stop with scale
- 2 pneumatic clamps and lubrication spraying device (M = spraying via hand pump)

Cutting range

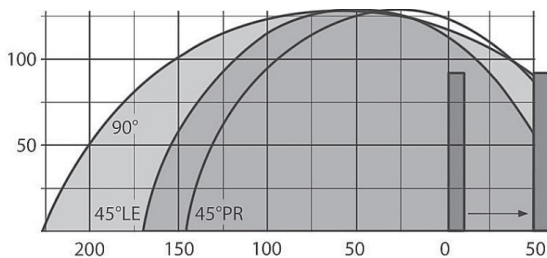

Mitre saw **GS 350 (M)**

- for aluminum and plastic profiles
- pneumatic saw feed with 2-hand operation (M = manual saw feed)
- saw cut from below, drive 2.2 KW, 400V / 50Hz
- 2 pneumatic clamps vertical (optionally also 2 horizontal clamps)
- miter left right with scale and grid points
- movable rear stop

Cutting range

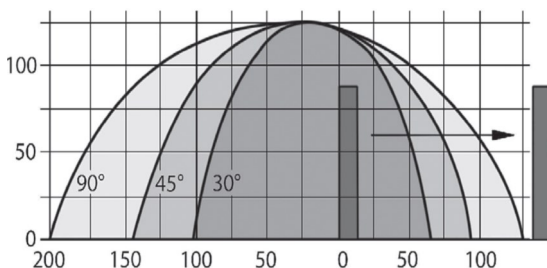

CIRCULAR SAWS

Mitre saws

Mitre saw **GS 600**

- for aluminum and plastic profiles
- for \varnothing 600 mm saw blades
- motor 5.5 KW, 400 V, 50 Hz, 3,000 rpm
- hydropneumatic saw feed, saw cut from bottom to top
- material cross lay swivel 20° - 90° - 20° with digital display
- grid locks at $22,5^{\circ}$ - 45° - 90°
- pneumatic profile clamping, vertical with 2 clamping cylinders
- pneumatic profile clamping, horizontal with 2 clamping cylinders
- clamping pressure regulation vertical and horizontal
- rear material stop can be moved 200 mm backwards
- stationary base, working height 970 mm
- pneumatic protective hood
- 2 chip extraction nozzles \varnothing 100 mm
- 24 V signal to control an external chip extractor
- air gun with spiral hose
- operation via 2-hand control
- minimum quantity lubricator with one nozzle
- max. cutting range:
 - profile height: 225 mm
 - profile width: 300 mm



Cutting area GS 600

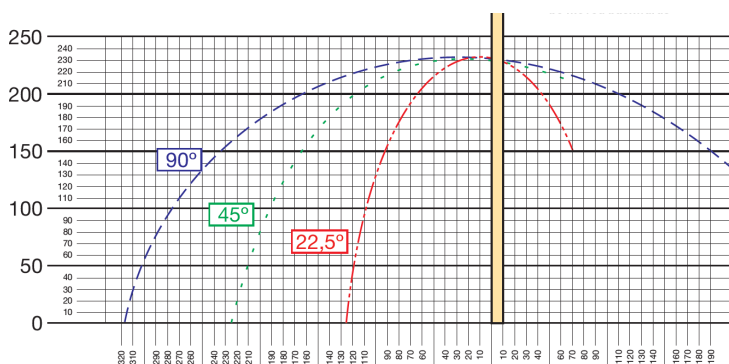

CIRCULAR SAWS

Mitre saws

Mitre saw **GS 800**

- for aluminum and plastic profiles
- for \varnothing 800 mm saw blades
- motor 7.5 KW, 400 V, 50 Hz, 3,000 rpm
- hydropneumatic saw feed, saw cut from bottom to top
- material cross lay swivel 20° - 90° - 20° with digital display
- grid locks at $22,5^{\circ}$ - 45° - 90°
- pneumatic profile clamping, vertical with 2 clamping cylinders
- pneumatic profile clamping, horizontal with 2 clamping cylinders
- clamping pressure regulation vertical and horizontal
- stationary base, working height 970 mm
- pneumatic protective hood
- 2 chip extraction nozzles \varnothing 100 mm
- 24 V signal to control an external chip extractor
- air gun with spiral hose
- operation via 2-hand control
- minimum quantity lubricator with one nozzle
- max. cutting range:
 - profile height: 320 mm
 - profile width: 450 mm



Cutting area GS 800

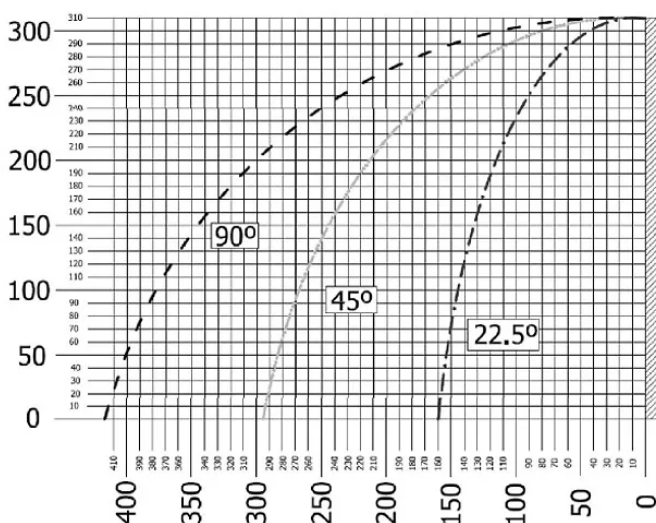

CIRCULAR SAWS

90° vertical cutting saws

Circular saw **GS 550**

- for aluminum and plastic profiles
- for Ø 550 mm saw blades
- motor 7.5 KW, S6, 400 V, 50 Hz, 2,850 rpm
- low-burr high-speed sawing, cutting speed 82 m/sec.
- hydropneumatic saw feed, saw cut from bottom to top
- pneumatic profile clamping, vertical and horizontal with 2 clamping cylinders
- clamping pressure regulation vertical and horizontal
- stationary base, working height 970 mm
- saw blade casing under the table top
- manual protective hood (pneumatic as option)
- 2 chip extraction nozzles Ø 100 mm
- potential-free contact for the control of a chip extraction
- operation via 2-hand control
- minimum quantity lubricator with one nozzle
- 1 litre lubricant tank with level monitoring
- noise protection package
- max. cutting range:
 - profile height: 190 mm
 - profile width: 350 mm



Cutting range

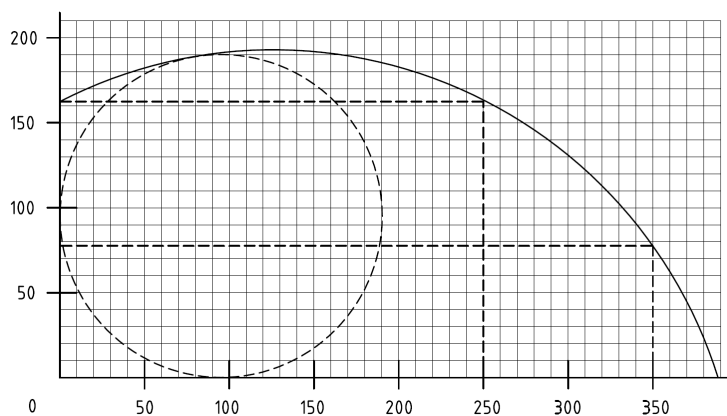

CIRCULAR SAWS

90° vertical cutting saws



Circular saw **GS 700**

- for aluminum and plastic profiles
- for \varnothing 700 mm saw blades
- motor 10.0 KW, S6, 400 V, 50 Hz, 1,300–2,000 rpm
- low-burr high-speed sawing, cutting speed 48-73 m/sec.
- saw blade speed control by converter and potentiometer
- hydropneumatic saw feed, saw cut from bottom to top
- pneumatic profile clamping, vertical and horizontal with 2 clamping cylinders
- clamping pressure regulation vertical and horizontal
- rear material stop can be moved ca. 150 mm forwards
- stationary base, working height 970 mm
- saw blade casing under the table top
- manual protective hood (pneumatic as option)
- 2 chip extraction nozzles \varnothing 100 mm
- potential-free contact for the control of a chip extraction
- operation via 2-hand control
- minimum quantity lubricator with one nozzle
- 1 litre lubricant tank with level monitoring
- noise protection package
- max. cutting range:
 - profile height: 270 mm
 - profile width: 530 mm



Cutting range:

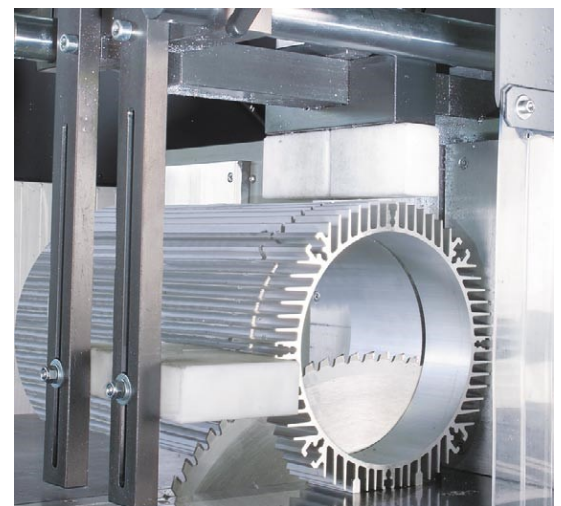
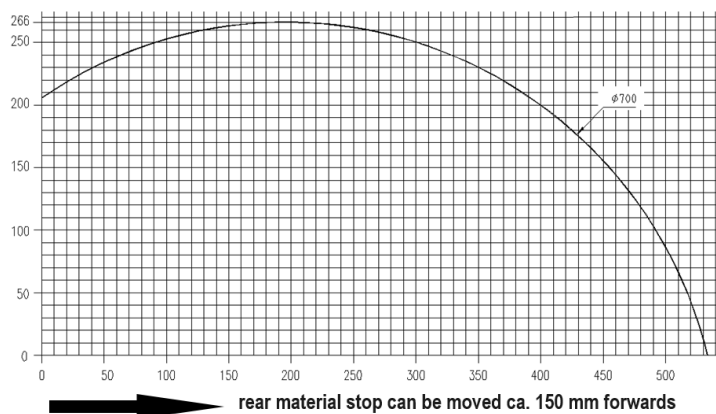

CIRCULAR SAWING LINES

90° vertical cutting saws

Automatic sawing line **GS 550 with pusher**

- design similar to GS 550 base model but with following additions:
- loading magazine with 5 line tooth belt drive with belt width of 32mm
- 4 compartments 230 mm wide, with driving cams (h x w) 40 x 14 mm
- 3 sliding supports between the toothed belts as additional support
- loading weight: max. 750 kg (equally distributed over the entire loading magazine)
- profile length: min. 1,500 mm, max. 6,500 mm
max profile width: 300 mm
max part length: 1,500 mm
- common drive of the lines via FU controlled gear motor
- lifting rollers with longitudinal alignment stations
- linear pusher that moves the profiles into the saw
- positioning with magnetic tape, tolerance +/- 0,15 / meter
- pneumatic gripper
- outfeed conveyor belt with continuous felt covering
- automatic separation of trim cut and rest piece
- good parts are transported further and either ejected through a bulk part gate to fall into a box, or pushed onto a manual pickup table by a cross-feeder
- Siemens S7-1500 control unit with touch screen 7"
- database for cutting data, date/time section length, number of pieces
- as option: profile takeover by a downstream system

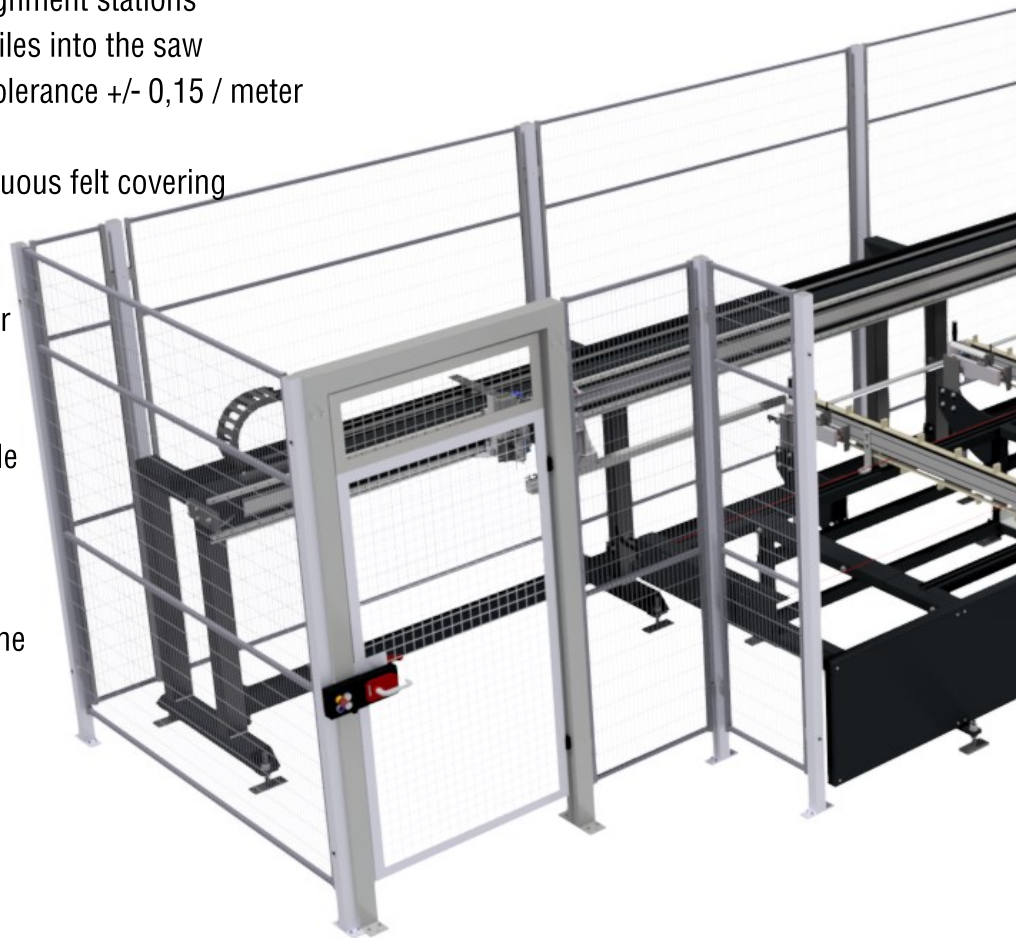
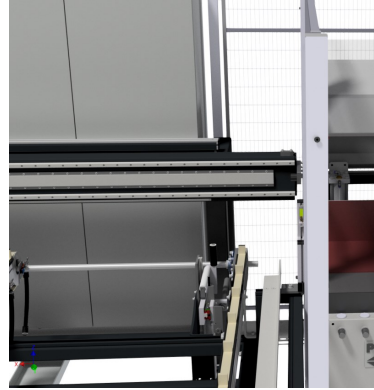

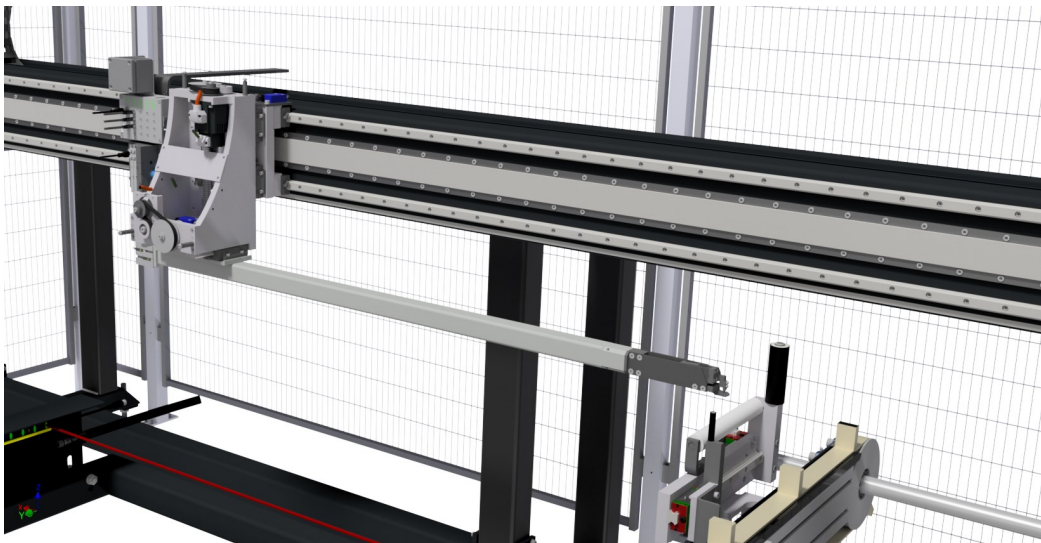
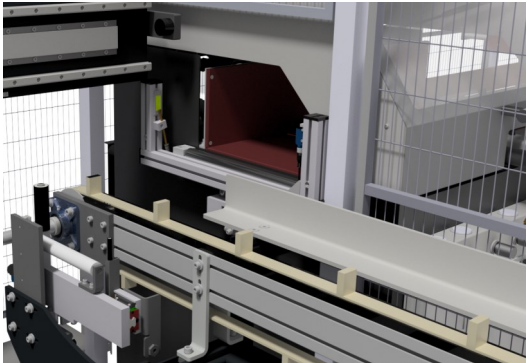
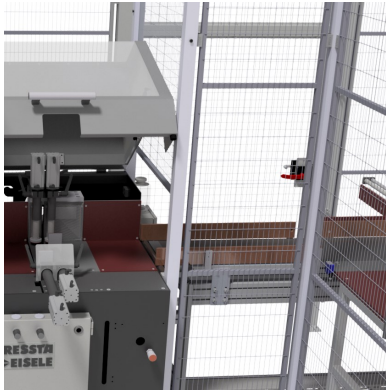

CIRCULAR SAWS

„plate saws“

PS 500 (60/65)

- for aluminum plates and profiles
- linear, horizontally moving saw feed with ball screw drive
- drive power 12KW, S6 60%, 400 V, 50 Hz, 2850 rpm
- vertical clamping bars on both sides of the saw blade
- minimum quantity spraying with one nozzle, 1 liter monitored tank
- pneumatically opening hood, 2-hand operation



Cutting range

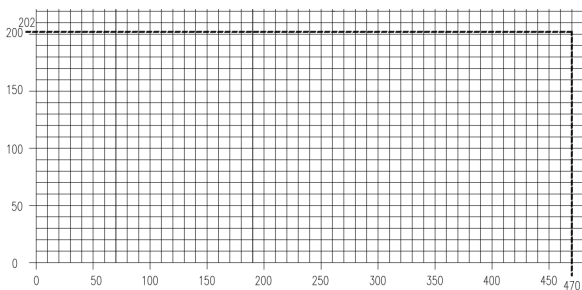

PS 1000

- for aluminum plates and profiles
- linear, horizontally moving saw feed with ball screw
- drive power 12KW, S6 60%, 400 V, 50 Hz, 2850 rpm
- vertical clamping bars on both sides of the saw blade
- minimal quantity spraying with a nozzle, 1 liter monitored tank
- pneumatically opening hood, infeed and outfeed table



Cutting range

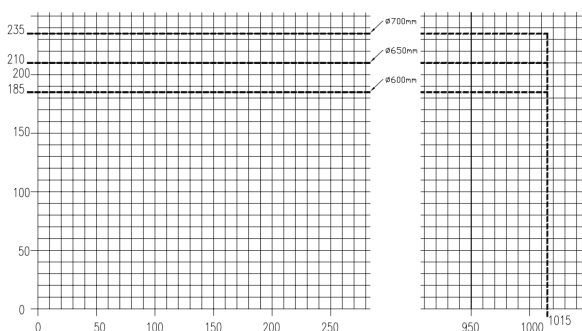

CIRCULAR SAWS

Accessories



Chip extractors

(from page 36)

- for different requirements
- mobile or stationary, with an integrated collection container, or for external collection containers

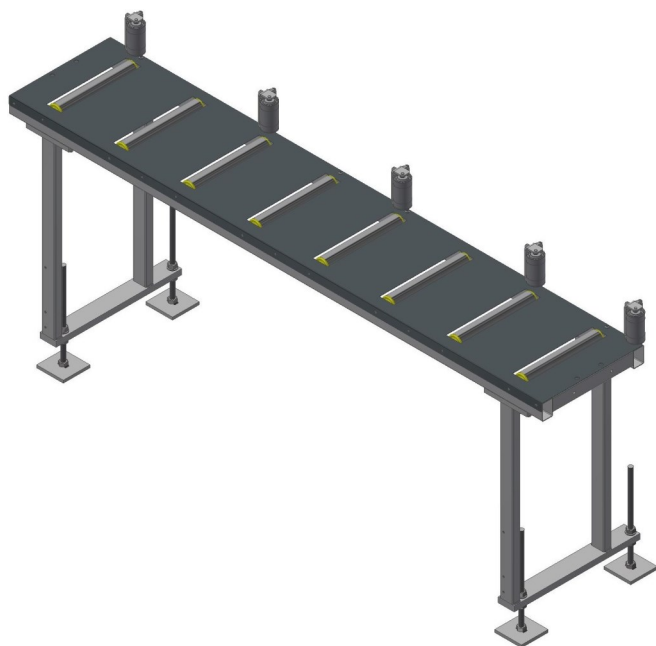

Roller conveyors

(from page 14)

- in various widths and lengths

Length measuring systems

(from page 15, 16)

- in various versions from purely manual to electric operated

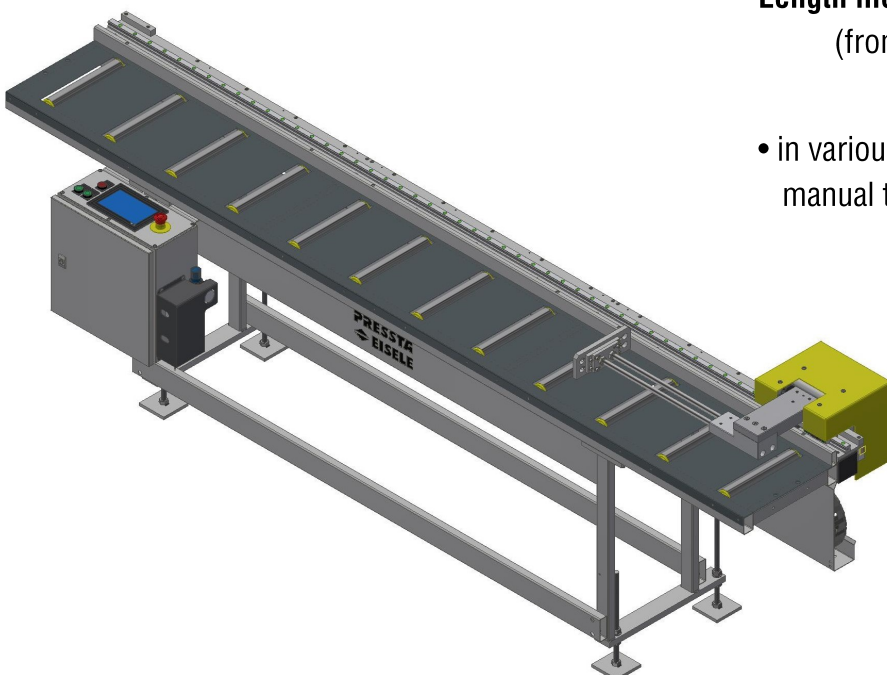

ROLLER CONVEYORS & LENGTH MEASURING SYSTEMS

Roller conveyors

RoBa 300 PVC

Roller conveyors for the transport of raw material or good parts

- single segment each 1 or 2 m
- conveyor width: 300 mm
- roller diameter: 50 mm PVC
- roller distance: 250 mm
- maximum load: 160 kg/m
- length: 1,000 or 2,000 mm
- working height: 784 – 1,044 mm

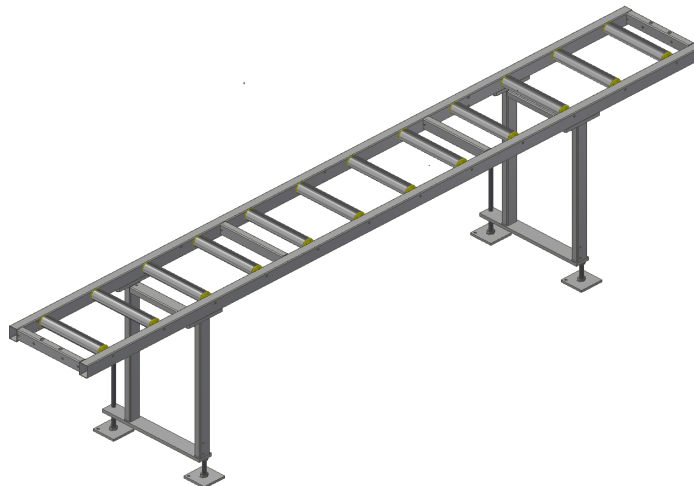

RoBa 500Steel

Heavy-duty roller conveyors for the transport of raw materials or good parts.

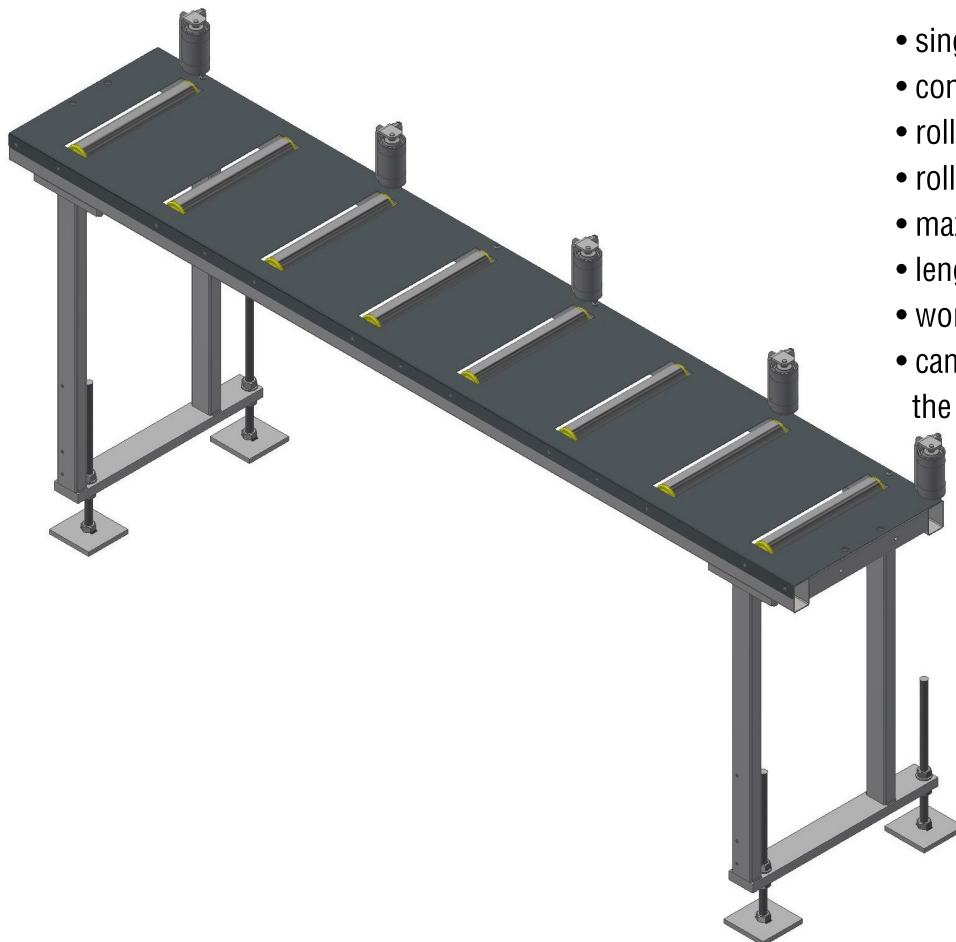

- single segment each 1 or 2 m
- conveyor width: 500 mm
- roller diameter: 50 mm steel
- roller distance: 250 mm
- maximum load: 200 kg/m
- length: 1,000 or 2,000 mm
- working height: 784 – 1,044 mm
- can be equipped with cover plates between the rollers

ROLLER CONVEYORS & LENGTH MEASURING SYSTEMS



Length measuring systems

PE-MS 300/500 M

Manuel Length Measuring System

- with support for right-sided mounting at a circular saw or punching machine
- incl. roller conveyor RoBa300/500 with PVC or steel rollers
- incl. foot, cover plates and digital display
- measuring length: 320 mm less than total length
- maximum load: 160/200 kg/m
- working height adjustable from 784 - 1,044 mm
- available up to a maximum measuring length of 6,680 mm
- optional: positioning via handwheel with fine adjustment **PE-MS 300/500 MH**

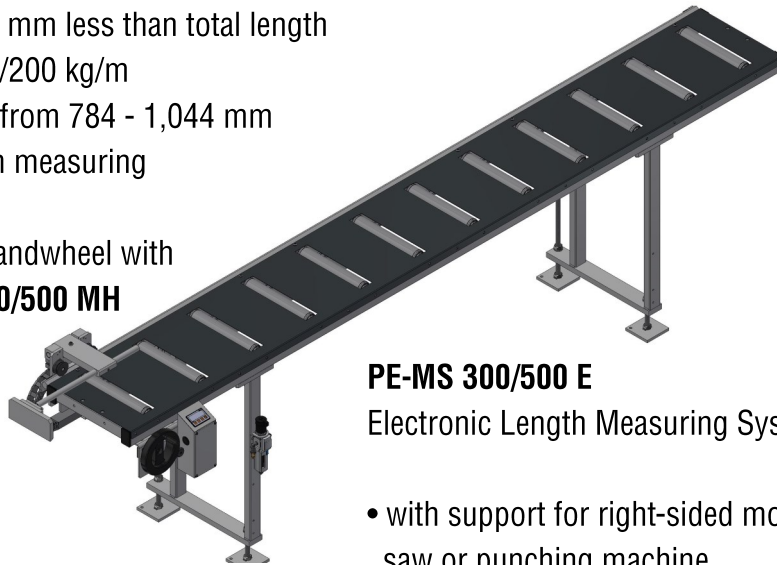
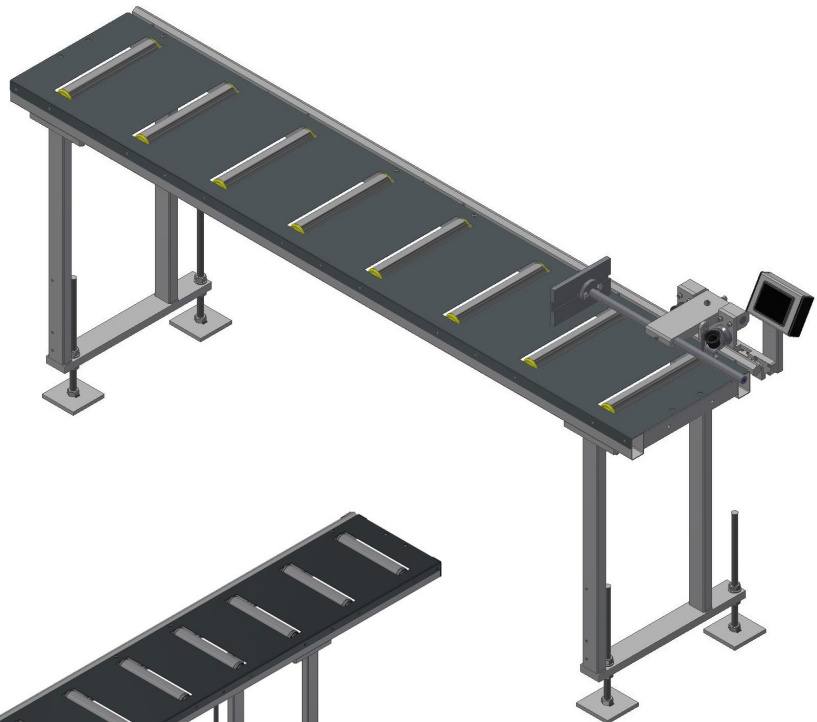

PE-MS 300/500 E

Electronic Length Measuring System

- with support for right-sided mounting at a circular saw or punching machine
- incl. roller conveyor RoBa300/500 with steel rollers
- incl. foot and cover plates
- incl. control, USB/LAN interface and retracting function
- measuring length: 500 mm less than total length
- maximum load: 160/200 kg/m
- working height adjustable from 784 - 1,044 mm
- available up to a maximum measuring length of 6,500 mm

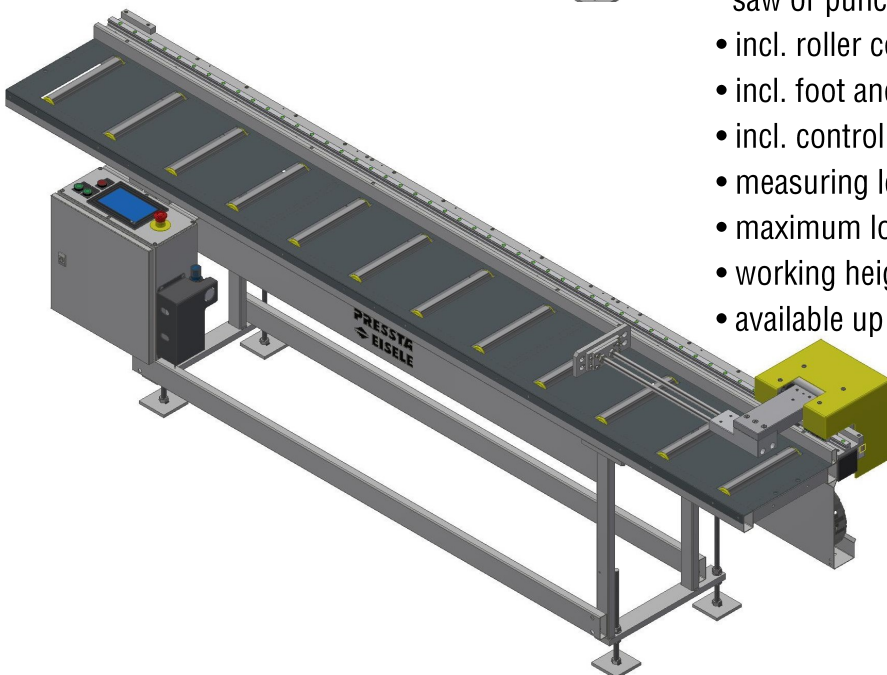

ROLLER CONVEYORS & LENGTH MEASURING SYSTEMS

Length measuring systems

NEDO mEsstronic

Electronic length measuring tool for manual measuring of inside dimensions of windows & doors

- with two measuring ranges 0.15—2.35 m and 0.803—3.00 m
- change between measuring ranges possible via keypress
- measuring accuracy 0.1 mm
- connection to TORNADO S length measuring system via bluetooth module



Measuring bench MD

Measuring bench for length measurement and optional angle measuring

- digital measurement of cut profiles
- stable aluminum construction with rail guide and slide table with aluminum profile width 180 mm
- 2 storage areas with hardwood panels
- measuring accuracy according to factory standard, tolerance $\pm(0,025 + 0,05 L) L[m]$

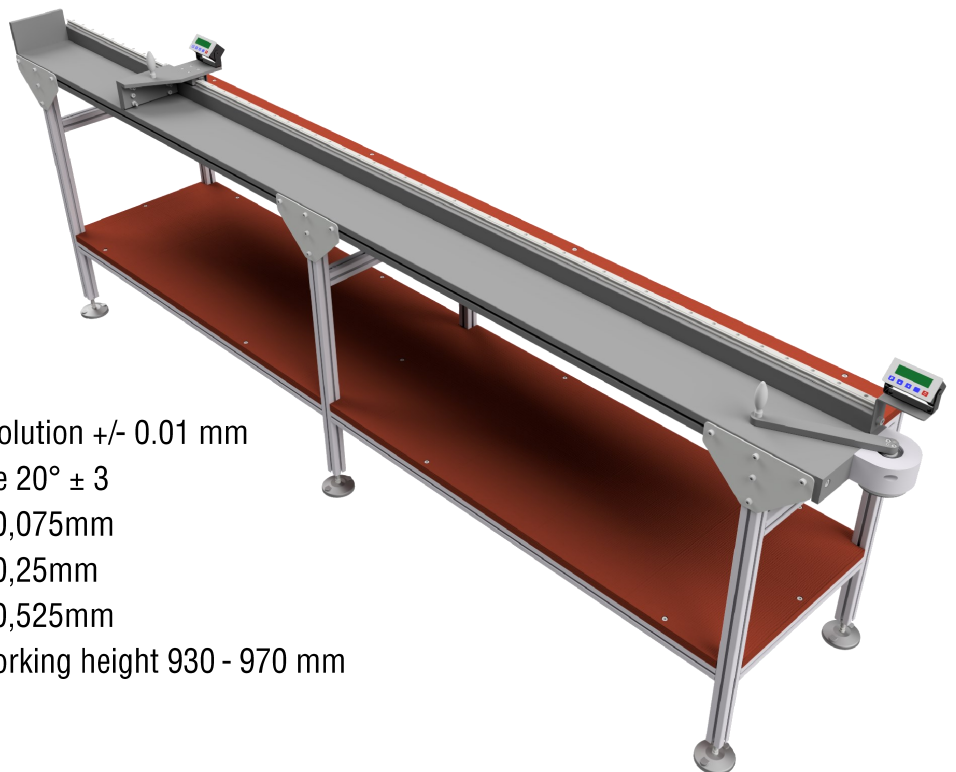

- control with digital display, resolution ± 0.01 mm
- tolerances at room temperature $20^\circ \pm 3$
 - measuring length 1m $\pm 0,075$ mm
 - measuring length 2m $\pm 0,25$ mm
 - measuring length 3m $\pm 0,525$ mm
- table with aluminum profile, working height 930 - 970 mm

NOTCHING SAWS



Prisma 500

- for processing aluminum and PVC profiles in facade and construction
- miters in 3 levels (can be used as a shift saw)
- manual adjustment of the horizontal saw blade
- by max. 20 mm in front of the vertical sheet
- notching options:
 - right-angled, mitre on one/both side(s),
 - mitre on three sides
- notch depths:
 - horizontally up to 185 mm at 90°
 - vertically up to 210 mm at 90°
- notch width:
 - at 90°: 300 mm, profile height up to 280 mm
- notch height adjustment manually, positioning via a scale tape
- swivel range saw blade vertical 30° - 90° - 30°, (front / middle / back) manually
- swivel range saw blade horizontally from 30° - 90° - 30°, manually
- positioning of the saw blades via mechanical digital display
- the material stop (table top) can be swiveled manually to the left and right, 30° - 90° - 30°, positioning via measuring scale
- the material depth stop is adjustable using a handwheel with sliding carriage and hand clamp, positioning via mechanical digital display
- semi-automatic sawing units, the profile remains firmly clamped during processing
- hydropneumatic feed, feed speed infinitely variable
- dosing spray device with 2 spray nozzles



NOTCHING SAWS

Prisma 650

- for processing aluminum and PVC profiles in facade and structural engineering
- mitres in 3 levels, as well as usable as a shift saw
- notching options:
right-angled, mitre on one/both side(s),
mitre on three sides
- notch depths:
horizontally up to 210 mm and vertically up to 262 mm at 90°
- notch width:
at 90° 280 mm, profile height up to 320 mm
- 4-axis NC control with motorized
- adjustment of the notch height, swivel range vertical, swivel range horizontal with vertical and notch depth,
- notch height adjustment motorized, positioning via control 0 - 260 mm
- swivel range saw blade vertical 90° - 60° + 30° (forwards / backwards) motorized
- swivel range saw blade horizontal with vertical saw blade 90° + 45° - 45°, motorized, positioning of the saw blades via control
- the material stop (table top) can be swiveled manually to the left and right, 30° - 90° - 45°, positioning via measuring scale
- material depth stop with motorized adjustment, positioning via control
- semi-automatic sawing units, the profile remains firmly clamped during processing
- hydropneumatic feed, feed speed infinitely variable

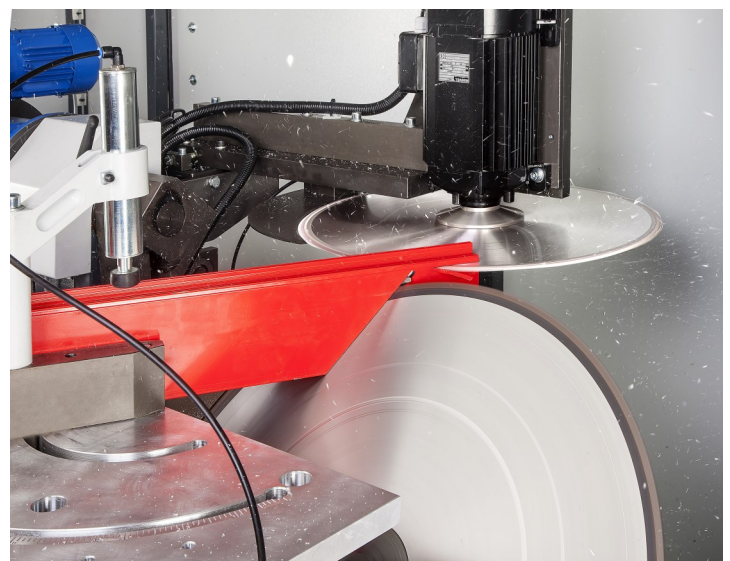

END MILLING MACHINES



Primus 300

- for finishing transom, mullion and transom profiles
- as well as other aluminum and plastic profiles, with side milling cutter
- milling packages or form milling cutters
- robust construction, with solid base
- manual milling process by hand lever
- drive 2.2 kW, 400V / 50Hz, 2800 rpm
- pneumatic material clamping including dosing spray device
- quick release device with hand lever
- including spacer rings 5x1mm, 1x5mm, 1x10mm, 2x20mm, 1x30mm
- milling spindle continuously adjustable in height 0-100mm
- material stop manually adjustable 20° - 90° - 20° with scale
- max.cutter diameter 300 mm,
- max. notch width / depth 400 mm at 90° / 110 mm
- max.profile height 190 mm, max.feed length 545 mm
- including maintenance unit
- working height 930 mm



Primus 300 PV

- for finishing transom, mullion and transom profiles as well as other aluminum and plastic profiles, with disc or form milling cutters, milling cutter packages.
- like Primus 300, but with:
- hydropneumatic milling process, infinitely variable feed speed, operation via a control panel, stroke length adjustable via limit switches
- max.feed length 570 mm

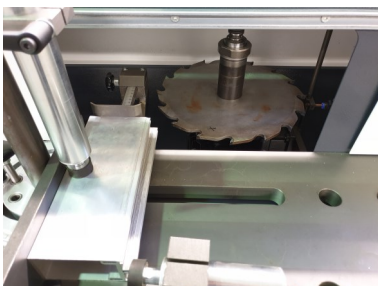

PUNCHING MACHINES

DYNO 6/9

- table punching machine (Dyno 6) and column punching machine (Dyno 9)
- drive: hydropneumatic with pressure intensifier
- high bending and torsional stiffness
- punching force 60 kN at 10 bar (Dyno 6)
- punching force 90 kN at 8 bar (Dyno 9)
- punching stroke:
35 mm (Dyno 6), 40 mm (Dyno 9)
- installation height w/o turntable:
≤ 220 mm (Dyno 6), ≤ 250 mm (Dyno 9)
- installation height with optional turntable:
≤ 200 mm (Dyno 6), ≤ 220 mm (Dyno 9)
- double strokes per minute
≤ 20 (Dyno 6), ≤ 22 (Dyno 9)
- working range: 130 mm ram to back wall
- foot valve operated



DYNO 15

- column punching machine
- hydraulic drive
- motor power: 4.0 kW
- high bending and torsional stiffness
- punching force: 160 kN at 200 bar
- punching stroke: 80 mm, can be limited downwards via scale
- installation height: ≤ 250 mm (w/o turntable)
- installation height: ≤ 210 mm (with turntable)
- double strokes: 14 / minute at maximum stroke
- working range: 130 mm ram to back wall
- foot valve operated
- stationary base, working height 935 mm
- options:
 - turntable to hold max. 5 tools
 - 2-hand control for hydraulic punching, with key switch to use the foot valve



PUNCHING MACHINES



DYNO 20/40 (A)

- column punching machine
- hydraulic drive
- motor power: 5.5 kW
- high bending and torsional stiffness
- punching force:
200 kN at 260 bar (Dyno 20), 400 kN at 260 bar (Dyno 40)
- punching stroke: 80 mm, can be limited downwards via scale
- installation height: ≤ 300 mm
- double strokes per minute
 ≤ 15 (Dyno 20), ≤ 12 (Dyno 40)
- working range: 200 mm ram to back wall
- foot valve operated
- stationary base, working height 935 mm
- design A with:
cycle spraying device with 2 nozzles for lubricating the hole punch
operation with adjustable key, selector switch with 3 positions
pos. 1 - operation via one foot valve
pos. 2 - operation via 2-hand control
pos. 3 - operation automatically via sensor release



DYNO 40/60

- punching machine for industrial use
- hydraulic drive
- motor power: 15 (DYNO 40) / 20 kW (DYNO 60)
- high bending and torsional stiffness
- punching force: 400 kN at 280 bar / 600 kN at 210 bar
- punching stroke: 40 mm
- installation height: ≤ 425 mm
- double strokes: 18 / minute (DYNO 40)
11 / minute (DYNO 60)
- working range: 200 mm ram to back wall
- operation via electric signal
(optional through foot valve or 2-hand control)
- 1 litre lubricant tank with level monitoring
- interfaces for compressed air and signal
exchange with the punching tool
- active oil cooler
- working table: (l x d) 450 x 400 mm

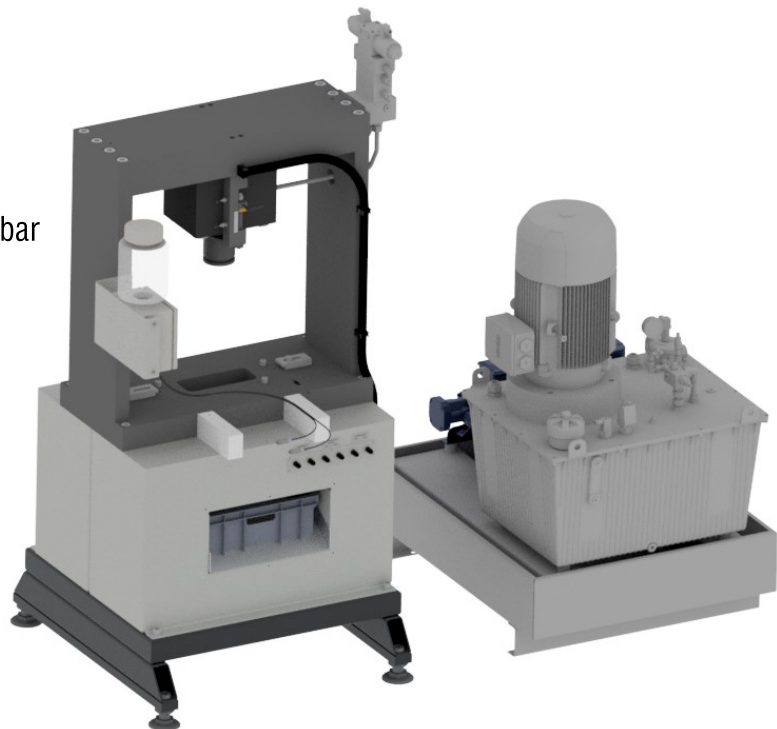

CORNER CRIMPING MACHINES

Pressta 5000

- corner crimping machine
- universally applicable by adjustable punching heads
- for corner cleat with groove size of 25 - 60 mm
- profile chamber offset: 0 - 40 mm
- stepless height adjustment of v-stop, knives and v-blocks
- v-stop and punching heads with scales
- hydraulic counter support with v-blocks
- pneumatic pressing process via leverage to ensure a synchronous punching process
- v-block height: ≤ 120 mm
- profile height: ≤ 190 mm
- pressing height: ≤ 150 mm
- profile width: ≤ 70 mm, profile projection: ≤ 60 mm
- smallest inside frame measure: 175 mm
- 2 vertical pneumatic cylinder to clamp profiles
- 2 Excenter disc for good positioning of profiles
- 2 profile support arms, swiveling
- foot pedal controlled

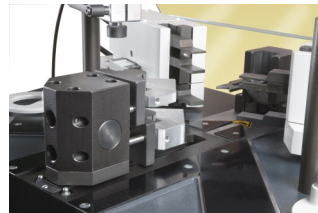

Pressta 7000

- design like Pressta 5000, but with:
- for corner cleat with groove size of 30 - 55 mm
- v-block height: ≤ 160 mm
- profile height: ≤ 205 mm
- pressing height: ≤ 180 mm
- profile width: ≤ 100 mm, profile projection: ≤ 55 mm
- smallest inside frame measure: 200 mm

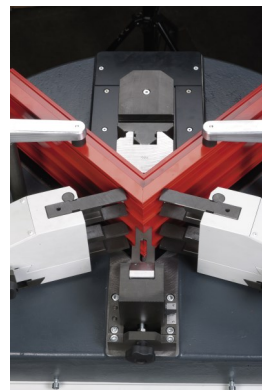

CORNER CRIMPING MACHINES



Pressta-Line

- orizontal automatic 4-head corner crimping system in a modular construction
- fully automatic corner crimping system with one fixed installed and three adjustable corner crimping heads

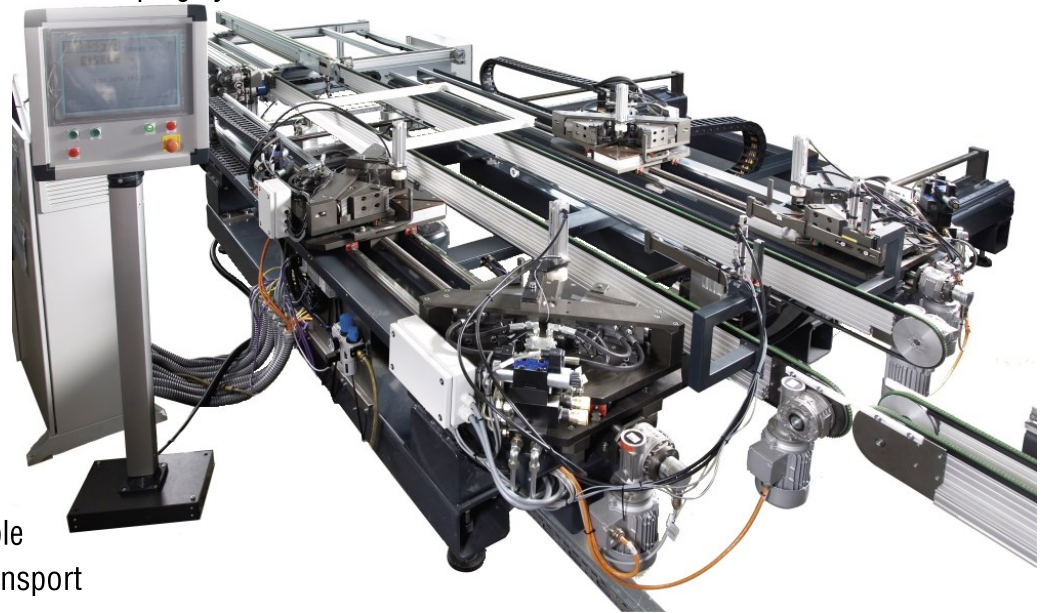

The window element is manually on the assembly table and is then transported by transport belts into the main unit.

There, the 4 punching heads automatically move towards the size of the window element, clamp the element with the integrated pneumatic clamps and crimp the corners.

The element is then released, the punching heads move back to their original position and the element is conveyed out of the system.

Optionally, the element can then be placed on a turntable, so it can be rotated for the injection of sealants before it is transferred to a tilting table.

There, the element is tilted from the horizontal to the vertical and ultimately transported to a storage unit.

- minimum possible frame size: 350 x 350 mm
- maximum possible frame size: 2000 x 3000 mm
- maximum punching height: 120 mm

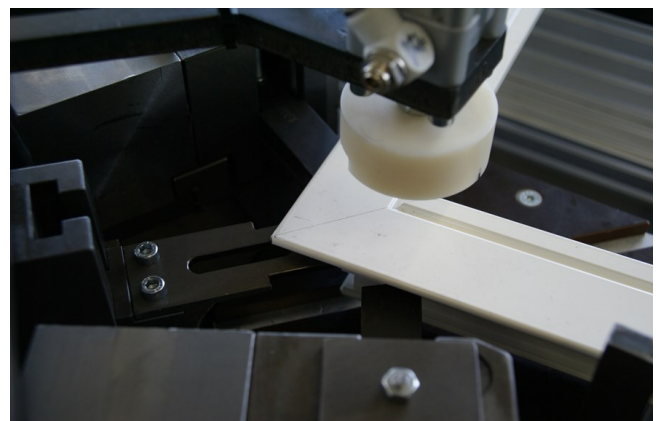

HIGH VOLUME MANUFACTURING OF CONNECTORS, CLIPS, ADAPTORS, etc.

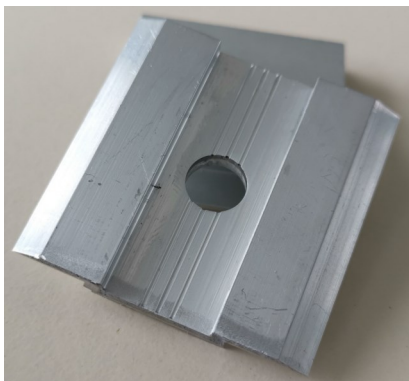
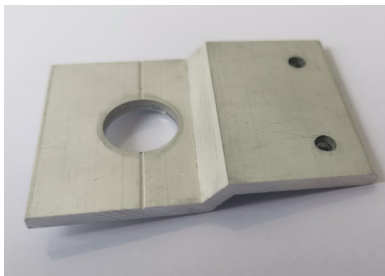
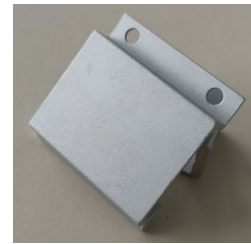
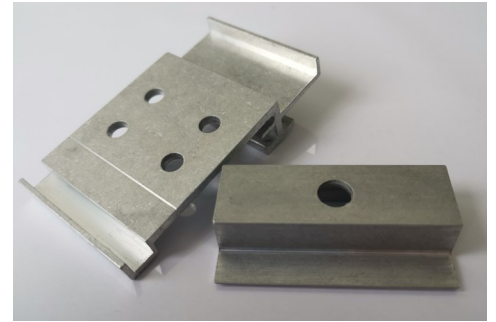

Machine combinations



Profilma 502 ST-V (ST-HV)

- for aluminum and plastic profiles
- cutting & punching combination
- Siemens S7 control unit with touch screen, incl. piece counter
- fully automatic operation
- motor 7.5 KW, S6, 400 V, 50 Hz, 2,850 rpm
- for Ø 500 or 550 mm saw blades
- motorised saw feed, saw cut from bottom to top
- kerf widening on both sides of the saw blade
- hydraulic punching device, right on the outfeed side
- punching force 300 kN vertical or punching force 2 x 150 kN vertical and horizontal
- punching stroke ≤ 20 mm
- hydraulic unit with oil cooler for industrial use
- ST-V for processing up to 4 profiles at the same time
- process sequences that can be selected via machine control:
 - positioning, sawing, punching
 - position, shear
 - positioning, punching, positioning, sawing, punching
 - positioning, sawing (with optional holding tool)

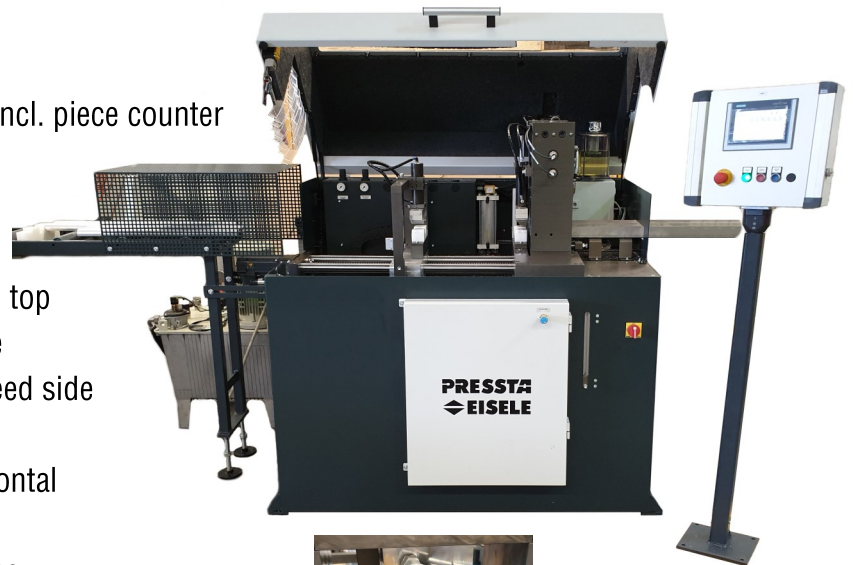

Profilma 502 BG

- cutting & drilling and tapping combination
- for aluminum profiles
- design like 502 ST-V, but with:
 - 2 drilling-tapping units right on outfeed side
 - portal with manually adjustable X-Y-Z axes
 - spindle distance: 35 mm
- drilling or drilling and tapping in one process followed by sawing and outfeed of the good parts
- operation can be either drilling followed by cutting or multiple drilling operations followed by a final cutting operation

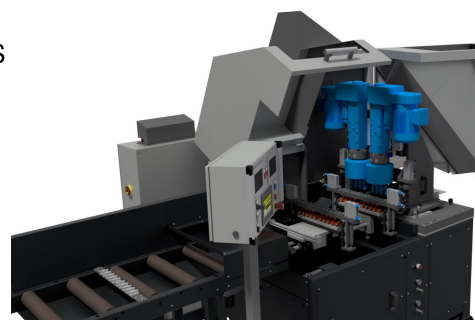

Machine combinations

Profilma 540 ST

- for aluminum profiles
- cutting & punching combination
- Siemens S7 control unit with touch screen, incl. piece counter
- fully automatic operation
- motor 7.5 KW, S6, 400 V, 50 Hz, 2,850 rpm
- for Ø 500/550 mm saw blades
- hydropneumatic saw feed
- saw cut from back to front
- hydraulic punching unit right on the outfeed side
- punching force 200/250 kN vertical
- punching stroke ≤ 20 mm
- double strokes: 20 / minute at maximum stroke
- hydraulic unit with oil cooler for industrial use
- for processing up to 8 profiles at the same time
- process sequences that can be selected via machine control:
 - positioning, sawing, punching
 - positioning, punching, positioning, sawing, punching
 - positioning, sawing (with optional holding tool)
- max. cutting range:
 - profile height: 58 mm
 - profile width: 400 mm

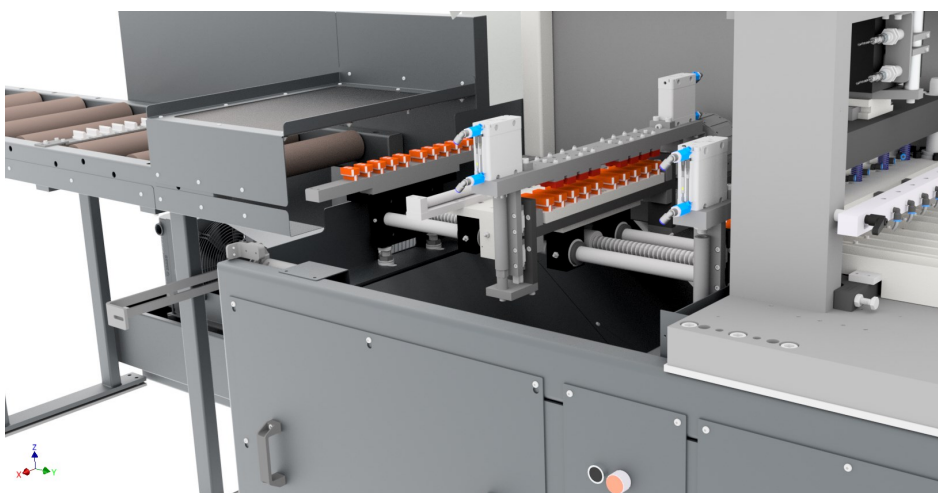
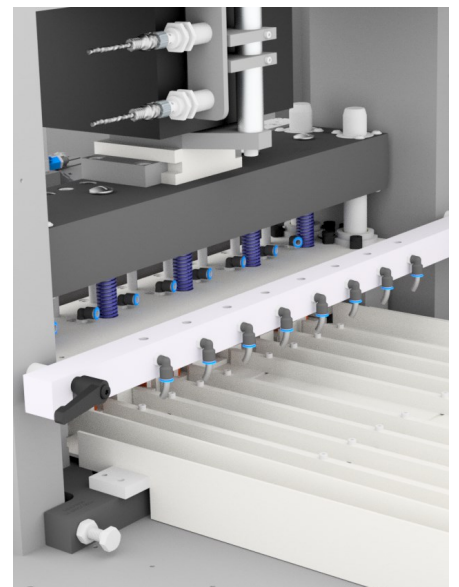

Machine combinations



Profilma 540 BG

- for aluminum profiles
- cutting, drilling and thread cutting of up to 8 profiles at the same time
- Siemens S7 control unit with touch screen, incl. piece counter
- fully automatic operation
- motor 7.5 KW, S6, 400 V, 50 Hz, 2,850 rpm
- for Ø 500/550 mm saw blades
- hydropneumatic saw feed, under table
saw cut from back to top
- feed length: 2 - 400 mm
- pneumatic profile clamping vertical
- clamping pressure regulation vertical
- saw feed speed infinitely adjustable ≤ 100 mm/sec.
- material feed unit with ball screw spindle and servo motor
- feeder carriage with round shaft guidance
- stationary base, working height 990 mm
- manuel protective hood
- drilling or drilling and tapping in one proces followed by sawing and outfeed of the good parts
- operation can be either drilling followed by cutting or multiple drilling operations followed by a final cutting operation
- 2 chip extraction nozzles Ø 100 and 160 mm
- potential-free contact for the control of a chip extraction
- minimum quantity lubricator with two nozzles
- 3 litre lubricant tank with level monitoring
- max. cutting range:

profile height: 58 mm

profile width: 400 mm

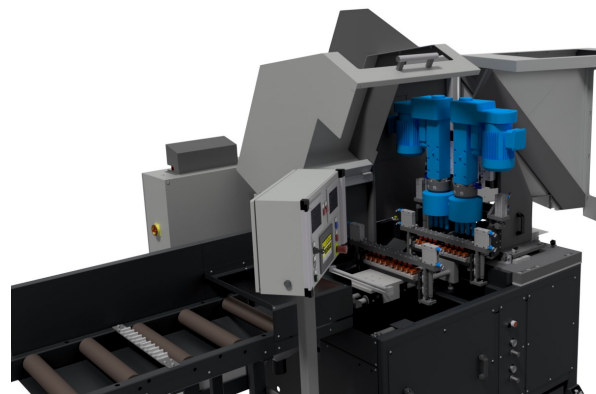
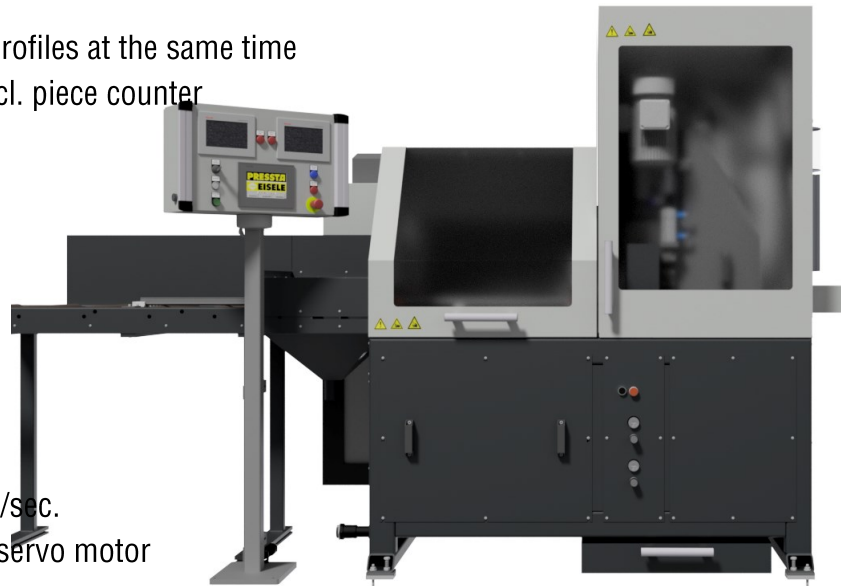

INDUSTRIAL MANUFACTURING OF PARTS

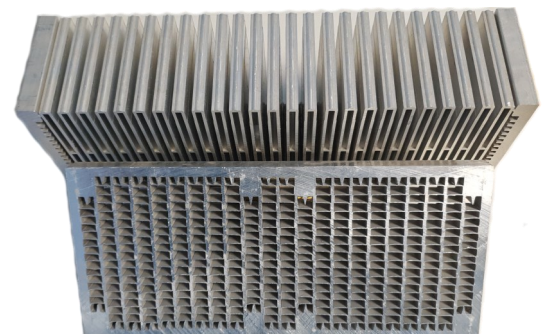
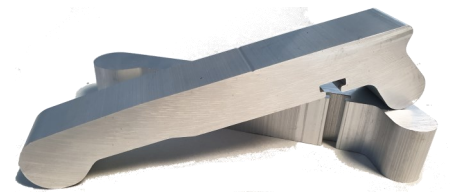
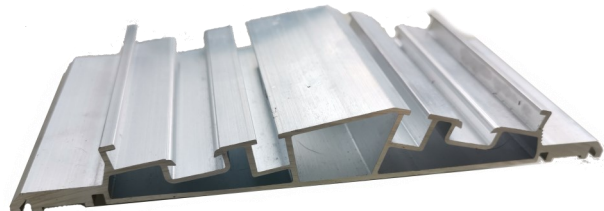
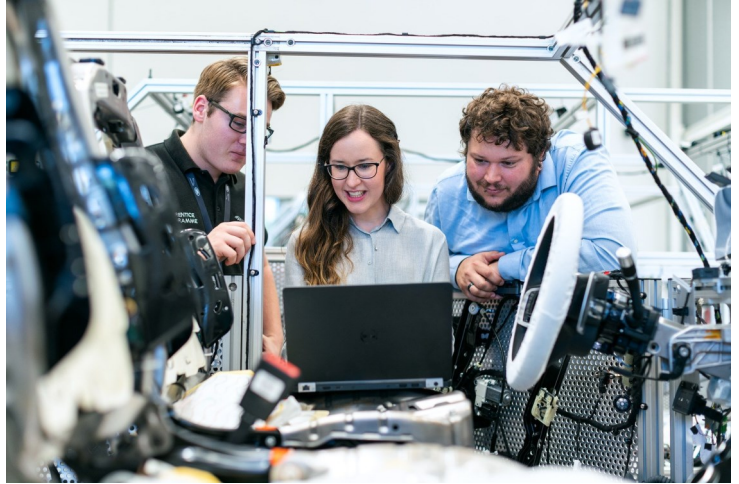

AUTOMATIC SAWS



Profilma 501 Comfort

- entry-level automatic saw
- fully automatic operation with a drive of 7.5 KW
- Siemens control HMI with 4" touch display, incl. piece counter and error diagnostics
- suitable for the use of 550mm saw blades
- saw blade feed is vertical from bottom to top, hydropneumatic and freely adjustable.
- pneumatic material clamps on the infeed and outfeed side of the saw blade, as well as a kerf widening function to reduce scratches on the cut surface.
- material feeder unit is equipped with a servo-controlled ball and screw drive
- feeder carriage with feed length of 3 - 600 mm
- cutting range of 270 x 140 mm or \varnothing 180 mm (hollow pipes)
- remaining piece length from 75 mm (depending on profile)
- minimum quantity lubricator with one nozzle
- 1 litre lubricant tank with level monitoring



Cutting range:

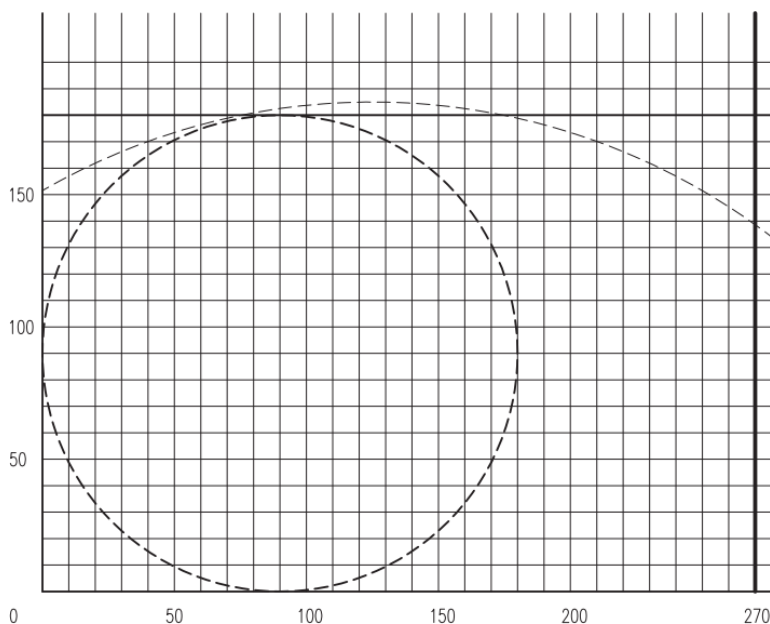

AUTOMATIC SAWS

Profilma 460

- for aluminum and plastic profiles
- fully automatic operation
- Siemens S7 control unit with touch screen, incl. piece counter
- error diagnosis incl. IXON Router for VPN connection
- quantity multiplier for usage of profile bundles
- cycle time information in seconds
- for Ø 460 mm saw blades (optionally 400mm)
- motor 12 KW, S6, 400 V, 50 Hz, 2,850 rpm
- infinitely adjustable speed control of the saw blade engine
- kerf widening on both sides of the saw blade
- feed length: 3 - 670 mm
- material feed unit with ball screw spindle and servo motor
- motorised saw feed, over table saw cut inclined from top to bottom
- feeder carriage is liftable and lowerable
- cut off lengths from 10 mm, from 3 mm with special clamping blocks
- cutting range of 250 x 148 mm
- minimum quantity lubricator with three nozzles
- 2 litre lubricant tank with level monitoring
- pneumatic protective hood
- 2 chip extraction nozzles Ø 100 and 160 mm

Cutting range:

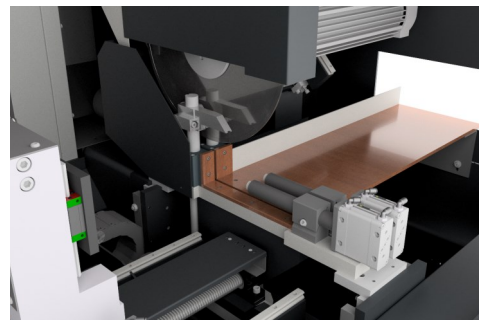
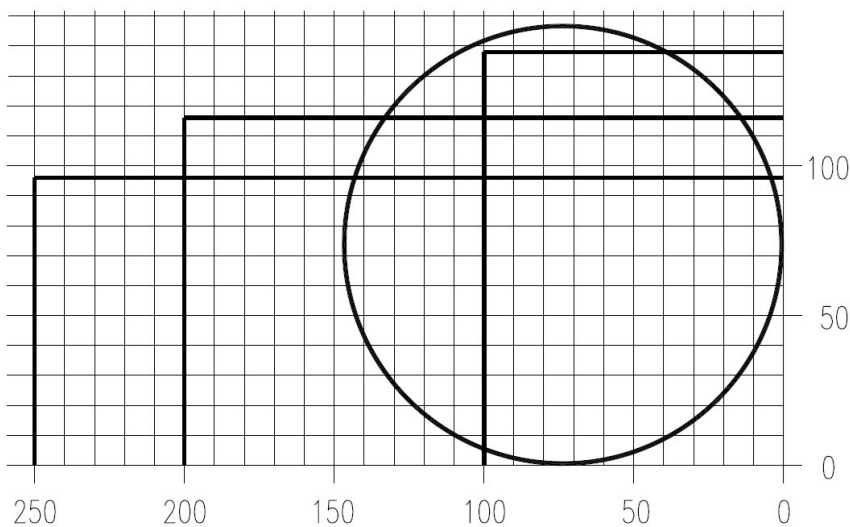

AUTOMATIC SAWS



Profilma 620

- for aluminum and plastic profiles
- fully automatic operation
- Siemens S7 control unit with touch screen, incl. piece counter
- error diagnosis incl. IXON Router for VPN connection
- quantity multiplier for usage of profile bundles
- cycle time information in seconds
- for Ø 600 or Ø 650 mm saw blades
- motor 18.5 KW, S6, 400 V, 50 Hz, 2,850 rpm
- kerf widening on both sides of the saw blade
- infinitely adjustable speed control of the saw blade engine
- feed length: 2 - 1,020 mm
- material feed unit with ball screw spindle and servo motor
- motorised saw feed, over table saw cut from back to top
- feeder carriage is liftable and lowerable
- cut off lengths from 10 mm, from 3 mm with special clamping blocks
- cutting range of 400 x 205 mm
- minimum quantity lubricator with three nozzles
- 2 litre lubricant tank with level monitoring
- pneumatic protective hood
- 2 chip extraction nozzles Ø 100 and 160 mm

Cutting range:

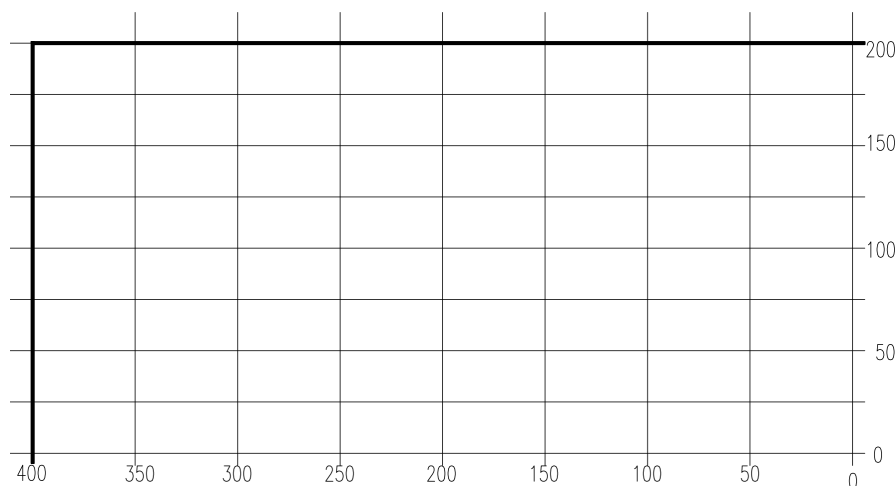

AUTOMATIC SAWS

ACCESSORIES



Shaker table

To transport parts while removing loose chips from the parts. The shaker table we offer has a pneumatic drive and a 100mm diameter chip

Roller conveyor

Available in different versions, depending on the saw to be used. We offer roller conveyors in 300 and 500mm width with PVC or steel rolls and with or without cover plates.

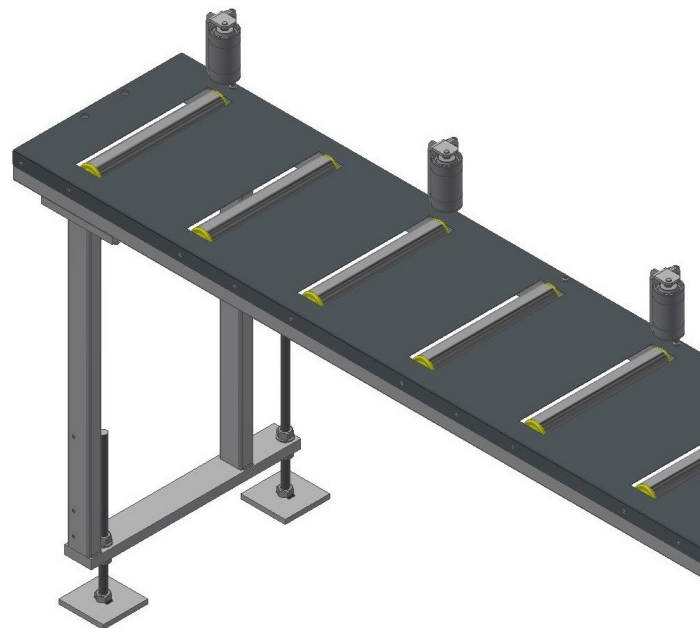

Loading magazines

We offer different type of loading magazines, tailored to the saw they are to be connected to, as well as to the type of profiles and operations. You will find more detailed information about the type of loading magazines available in our standard range on the following pages.

AUTOMATIC SAWS

ACCESSORIES



Material outfeed stations

From the simple outfeed belt, transporting the cut parts out of the saw and into a box, to the electronically controlled multi-belt outfeed system that transports, separates and aligns the parts, transports them onto a pickup or buffer table, or facilitates the transportation of parts to a downstream production system.

We offer a wide range of standard outfeed stations as well as custom solutions.

Automated material handling

We offer various solutions for automatic material handling.

From the handling of single profiles or the automatic unloading of production lines with a robot, to automated gripper system capable of handling a bundle of profiles simultaneously, we offer project specific tailor made solutions for various requirements.

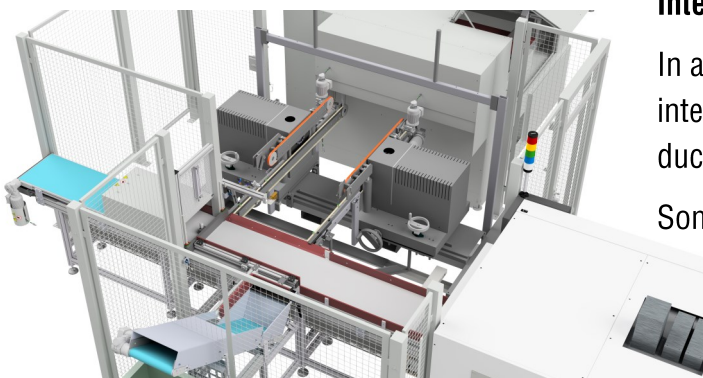

Integrated processing steps

In addition to cutting the profiles to length, we can also integrate further material processing steps into our production lines.

Some examples of such processing steps would be the sorting of parts between good and bad ones, the identification of profiles through camera systems, measuring of part lengths or marking of profiles with needle or laser markers. Even further processing steps like punching or drilling, milling and tapping can be integrated in the production process.

LOADING MAGAZINES

Loading magazine

- for aluminum and plastic profiles
- 5 strand toothed belt conveyor a single gear motor by a frequency converter
- compartment distribution via driver cams, according to the cutting area of the sawing system used
- control panel for setup mode, magazine “empty” sensor and pneumatic feed for transferring the profiles to the sawing system
- profiles with a length of min. 1,600 and max. 6,700 mm can be processed, as well as an evenly distributed total weight of 750kg

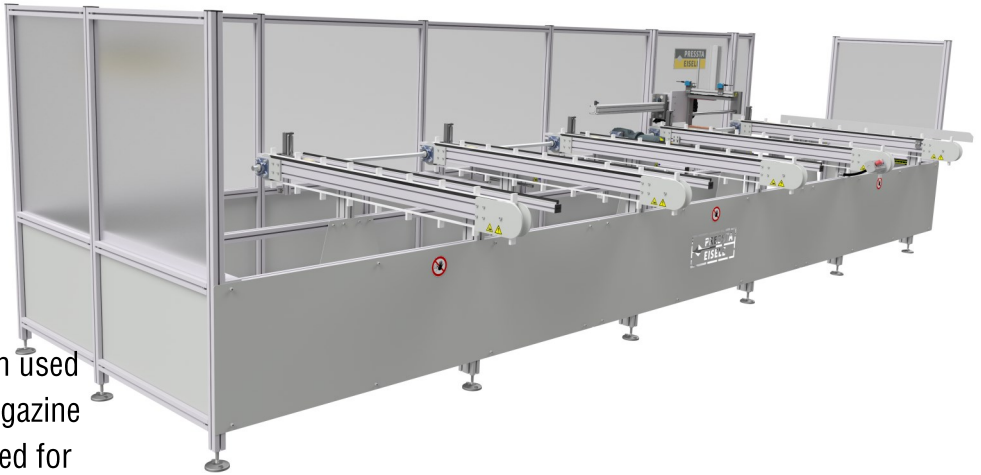

Horizontal chain conveyor HKF

- for aluminum and plastic profiles
- heavy duty version of the above standard loading magazines
- toothed belt conveyors have been replaced by drive chains with rubber pads.
- lifting cylinders and support rollers are installed in the rearmost loading position
- support rollers in the position of the first compartment in order to simplify the alignment of the raw profile bars
- a reinforced substructure allows the processing of profiles with an evenly distributed total weight of up to 2,500 kg

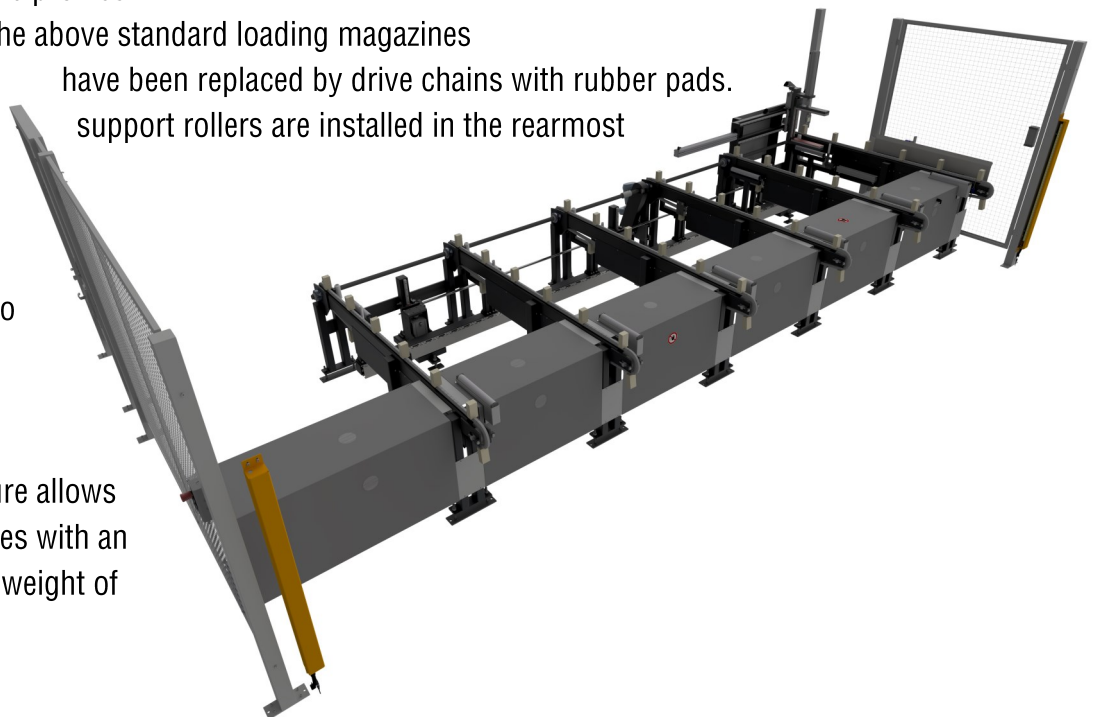

LOADING MAGAZINES



Bundle loading magazine

- for aluminum tubes with a diameter of 20-85 mm
- for attachment to the feed side on the left of the automatic saw
- complete bundles of aluminum tubes can be placed in the belt recess from above
- maximum bundle Ø: approx. 650 mm
- maximum bundle weight: 4,000 kg
- maximum pipe length: 6,200 mm
- pre-storage with separation and manual range setting behind the belt recess
- belts are driven by a single motor
- pneumatic separation and feed into the saw

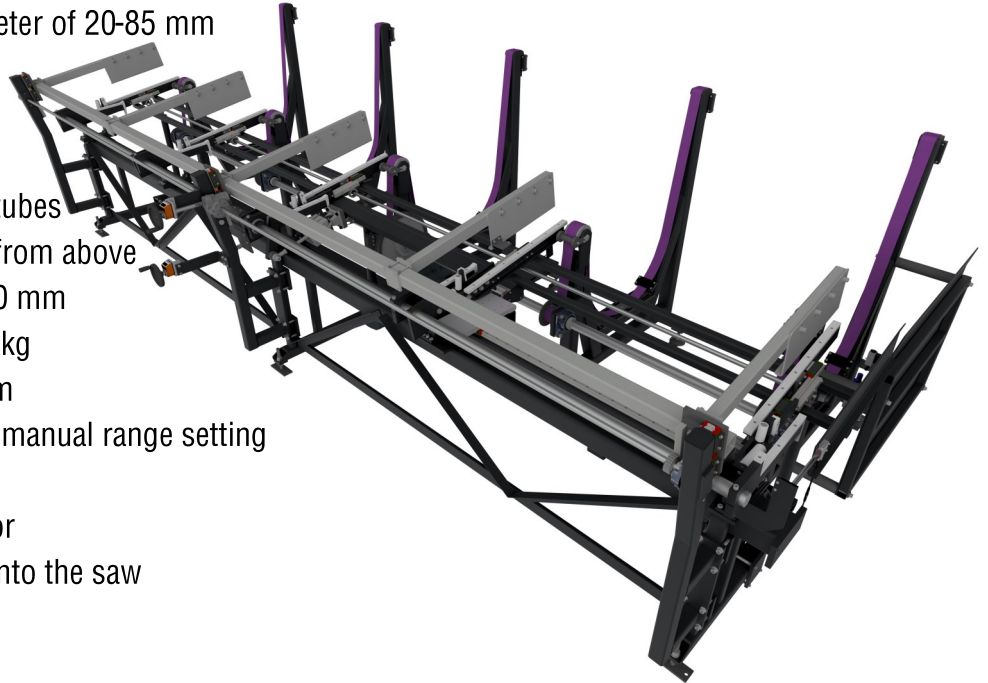

Loading aid lifter 100

- for dimensionally stable aluminum and plastic profiles
- lifting aid for placing profiles on roller conveyors or loading magazines
- for use of one person without the aid of a crane
- pneumatic lifting of the conveyor belt with adjustable stops
- with stroke of 250-1,050 mm and a 50 mm wide transport belt
- belt speed: approx. 150 mm/sec.
- boom length: 1,000 mm
- maximum profile weight: 50 kg
- working method:

A profile is pushed against the contact surface, the profile is lifted, then transported towards the storage area, deposited there and the belt moves down again.

- can be converted to transport the profiles to the left or right
- adjustable semi-automatic or automatic operation



CHIP EXTRACTORS

MG3

- mobile chip extractor MG 3 with oil separator
- dust and chip extraction into a 172 ltr. metal box
- collecting container can be released for easy emptying
- 2 inlets with nozzle Ø 100 mm
- motor 3.0 KW, 400 V, 50 Hz
- max. performance 2,600 m³/h
- ventilating worm casing above the extractor
- large filter with big surface
- pneumatic shaker unit for filter cleaning
- continuous operation or controlled by saw
- noise level: 80 dB(A)

MG3 - ATEX

- can be used for highly flammable chips and dust
- with Antistatik, Atex ZONE II 3D T135° 0:40°C

MG4

- mobile chip extractor MG 4 with oil separator and silencer
- dust and chip extraction into a 172 ltr. metal box
- collecting container can be released for easy emptying
- 2 inlets with nozzle Ø 160 mm
- motor 4.0 KW, 400 V, 50 Hz
- max. performance 4,000 m³/h
- ventilating worm casing above the extractor
- large filter with big surface
- pneumatic shaker unit for filter cleaning
- continuous operation or controlled by saw
- noise level: 80 dB(A)



CHIP EXTRACTORS



MG9VA

- high-performance chip extractor MG 9 with oil separator
- dust and chip extraction into a customer's own container
- 2 inlets with nozzle Ø 160 mm
- motor 4.0 KW, 400 V, 50 Hz
- max. performance 4,000 m³/h
- centrifugal fan with silenced housing
- automatic flow opener (rotary valves)
- continuous operation or controlled by saw
- noise level: ≤ 80 dB



SAWING LINES

KS 600/650/700/800

- for aluminum and plastic profiles
- fully automatic operation
- for profile lengths of 2,000 - 7,300 mm (standard version)
- with cut-off lengths from 10 - 7,200 mm
- 2 separate unloading stations
one for small parts up to 500 mm
one for long goods, which is divided into 2 parts and allows an outfeed over 2 x 3,500 mm or 1 x 7,200 mm
- extremely flexible saw line, characterized by its minimal set-up times through automatic adjustment to profile geometries
- large sawing area and the possible integration of further processing steps such as measuring, marking, deburring or automated loading / unloading



- processable profile dimensions as standard with the KS600 / 650 / 700 / 800R:

max. width:	10 - 350 / 470 / 475 / 450 mm
max. height with vertical clamp on the outfeed side:	180 / 205 / 230 / 280 mm
max. height without vertical clamp on the outfeed side:	210 / 235 / 260 / 320 mm
maximum raw profile bar weight:	30 / 35 kg/meter

- tolerances section:

10 - 1,000 mm part length:	+/- 0.15 mm
1,000 - 2,000 mm part length:	+/- 0.20 mm
2,000 - 5,000 mm part length:	+/- 0.30 mm
5,000 - 7,200 mm part length:	+/- 0.50 mm

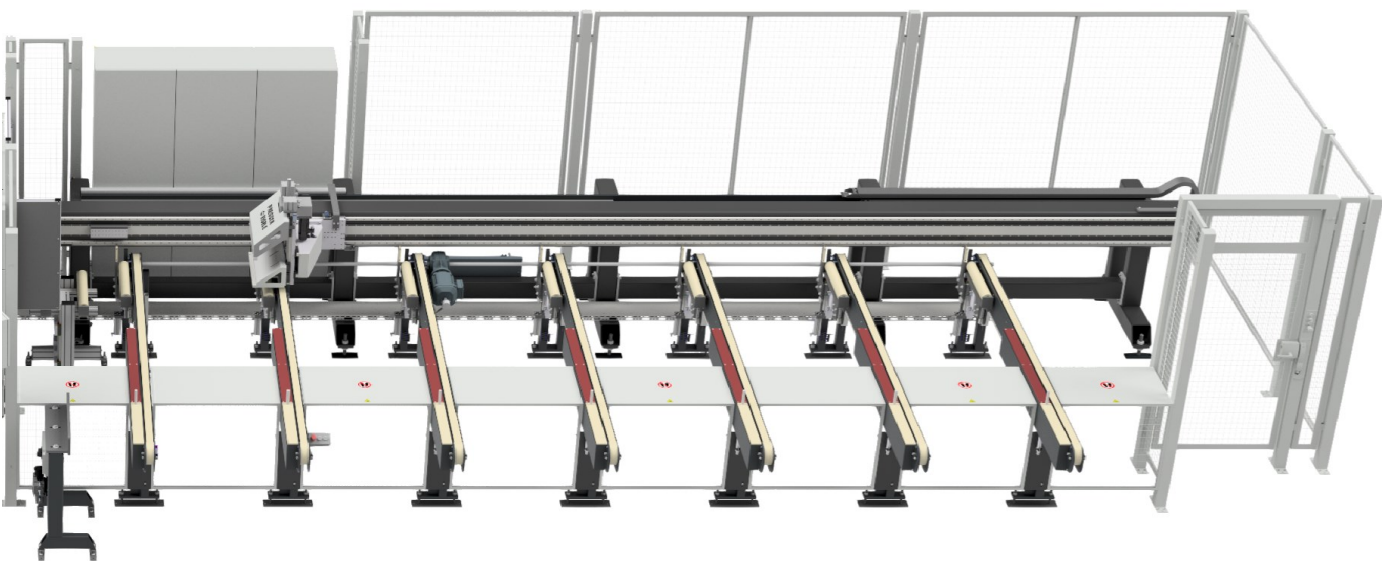

SAWING LINES

SW 600

- for aluminum and plastic profiles
- automatic sawing unit for 90° and mitre cuts
- sawing angle left 22.5° - right 157.5°, stepless
- pneumatic gripper traveling in Y and Z direction by motor via the internal database, which makes manual conversion of the system largely superfluous when changing professionals
- raw profile lengths: 1,000 - 7,000 mm (longer profiles on request)
- max. loading weight 75 kg/bar
- with its outfeed gripper, the SW600 is still able to hold the material to be sawn after the cut and to reposition it, which makes it possible to have saw combinations consisting of several cuts at both profile ends
- horizontal cross loader with linear movable pusher for positioning the material to be sawn, as well as an electrically driven saw feed axis, through which a precisely adjustable saw path and the shortest cycle times are achieved



- processable profile dimensions:
 - max. width: 168 mm
 - max. height depending on the cutting angle: see cutting diagram
 - smallest inside dimension at 90°: 90 mm
 - smallest inside dimension at 45°: 160 mm
 - smallest inside dimension at 22.5°: 390 mm
 - largest external dimension: 4,000 mm
- saw angle left / right: 22.5°-157.5°
- tolerances section: per 1000 mm travel: +/- 0.15 mm
- saw motor: 5.5kW, S6 60%, Hz, 400V
- saw blade Ø: 600 mm

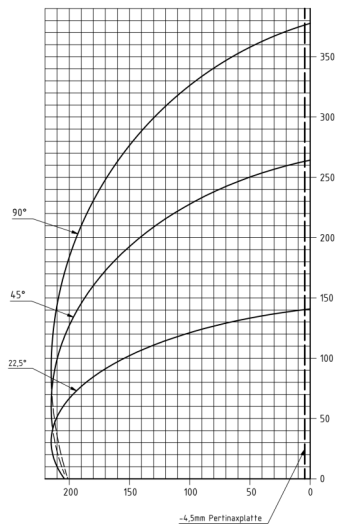
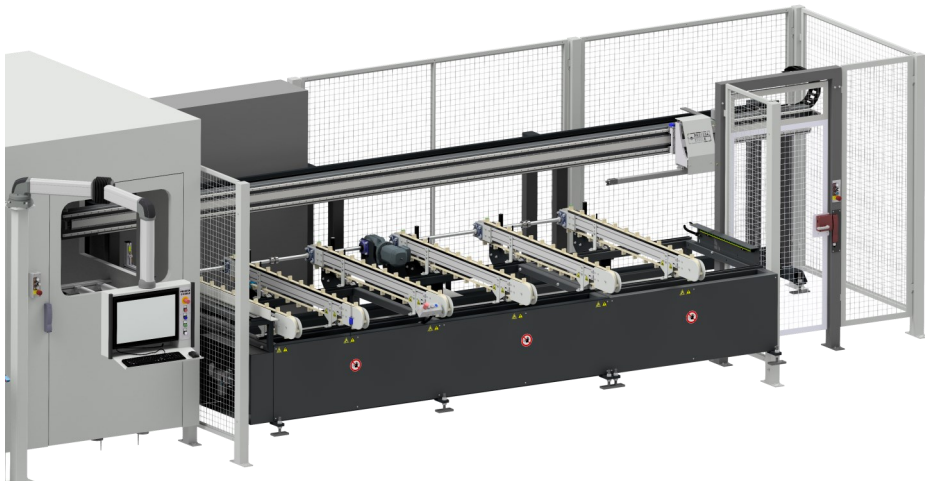
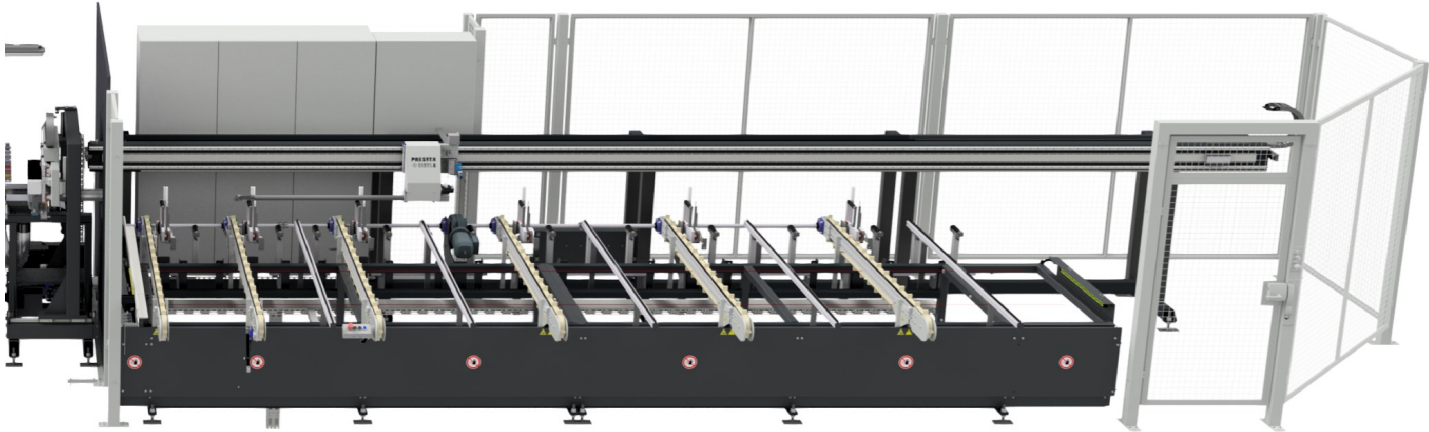

SAMPLES OF SPECIAL PURPOSE MACHINES

KS 600 R-S

Fully automated sawing line with automatic unloading of raw profile transport baskets, automatic setup of the saw and fully automatic laser marking with a QR code generated in-line with the production

Including QR code checking device for legibility checking of the QR code.

Cycle time at a part length of 1,8 m: 17 seconds

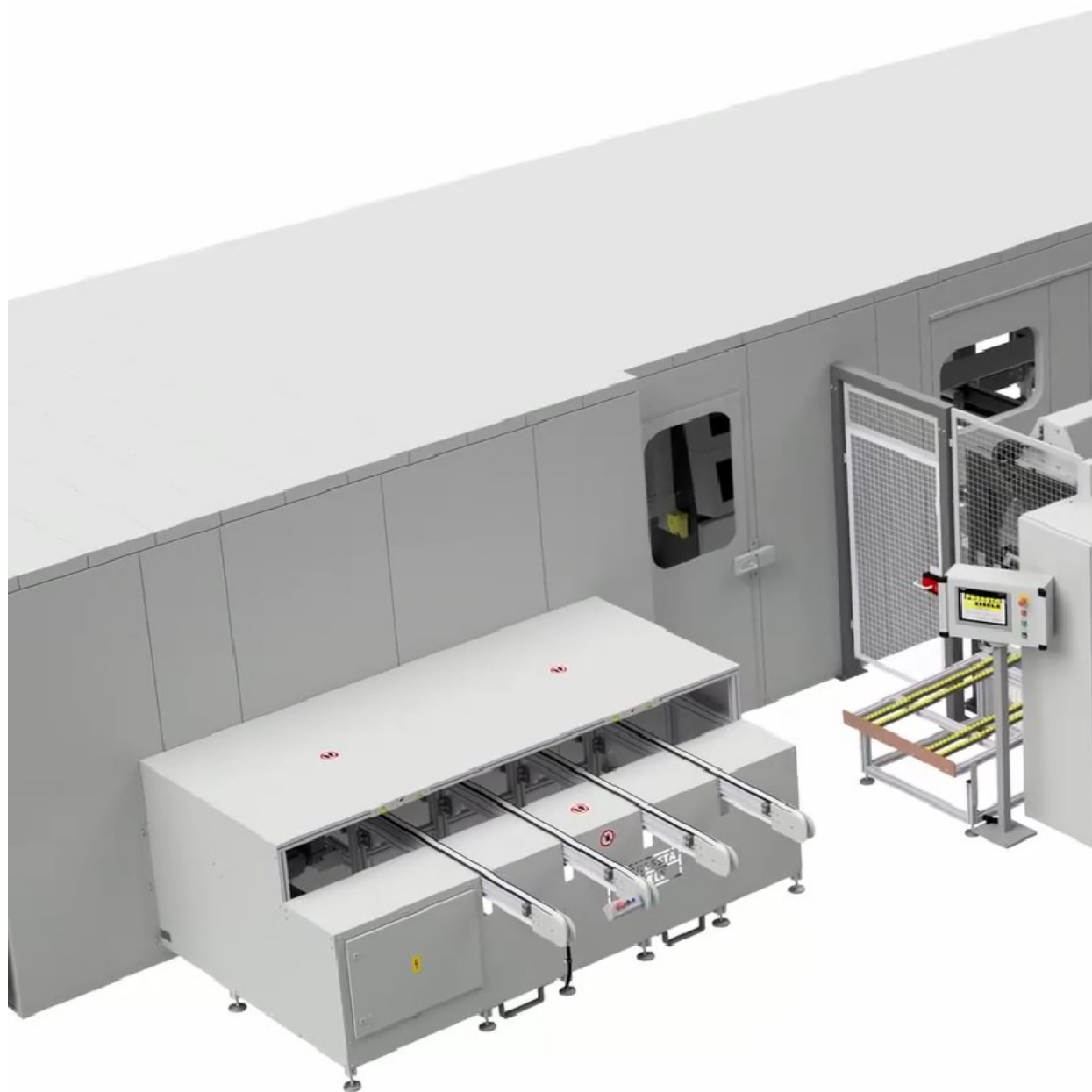

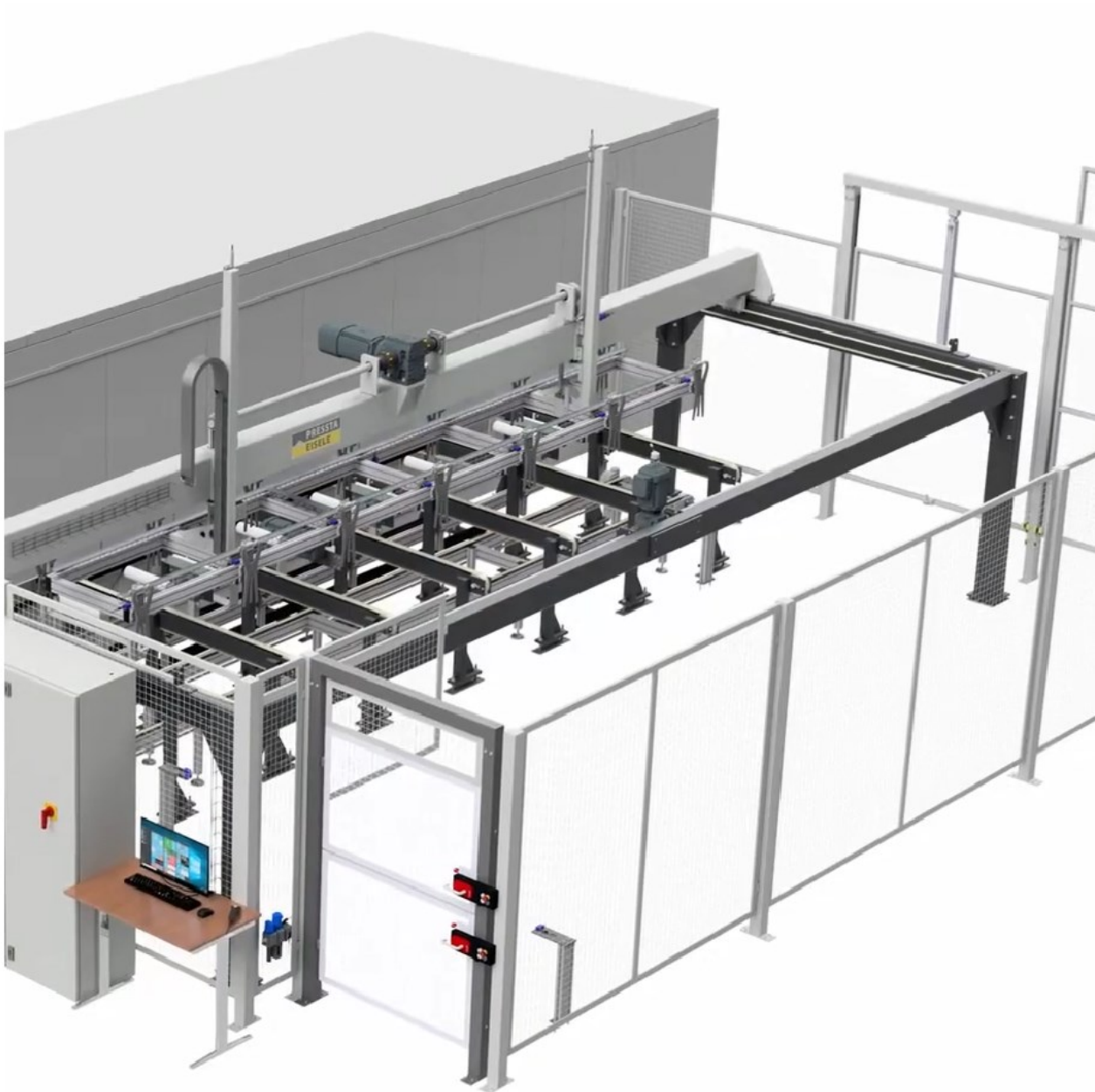

SAMPLES OF SPECIAL PURPOSE MACHINES

Profilma 620 production line with 2 handling robots

This production line for automatic processing of brackets in different sizes has a loading magazine to feed the raw profile bars into the saw. The Profilma 620, with its own internal material feeder, takes the bar and positions it precisely to the sawing position to achieve the lowest possible length tolerances.

The cut parts are then transported out of the saw to a trim-cut and rest piece separator. Past the separator a conveyor belt moves the parts towards an alignment station, from where a robot, depending on the program, puts the profile either in a punching unit or in a drilling and tapping station. Afterwards, a second robot takes the parts and places them either in a second channel of the punching machine, or takes them out and deposits them on a further conveyor belt that transports the parts out of the production line.

With this production line complex parts with holes / threaded holes can be made within 10-16 seconds.

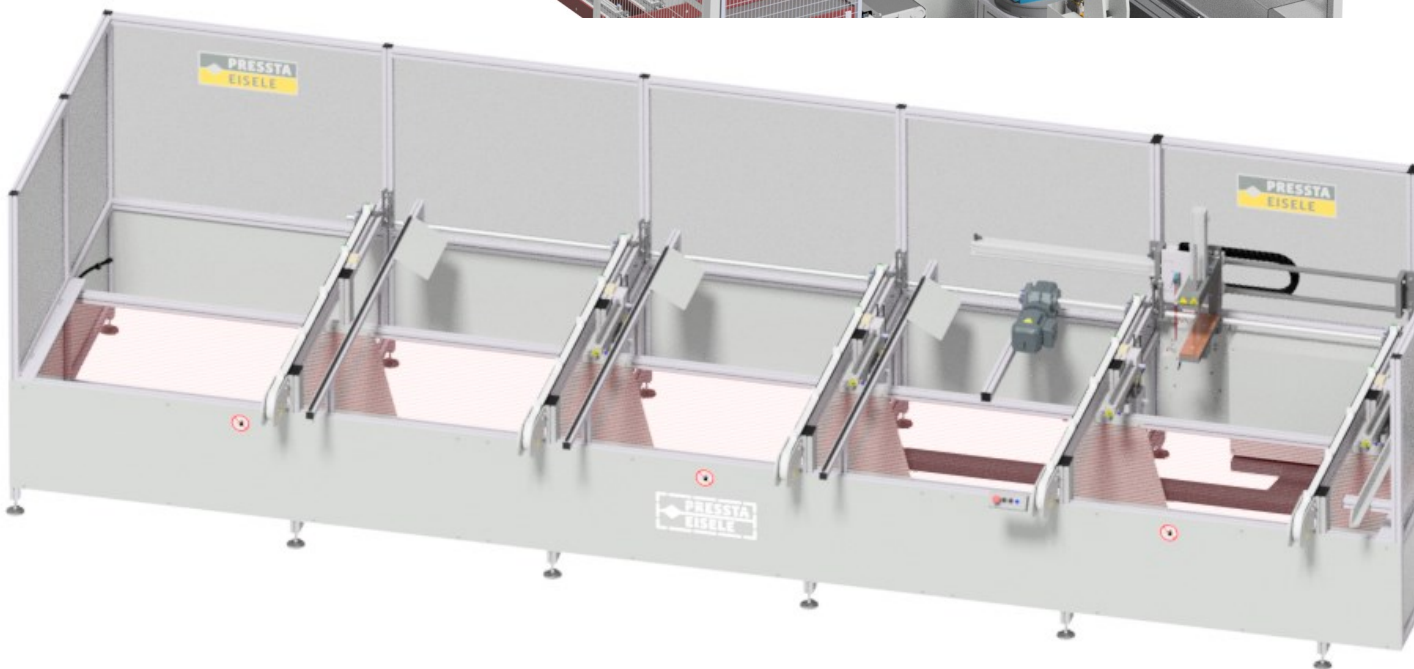
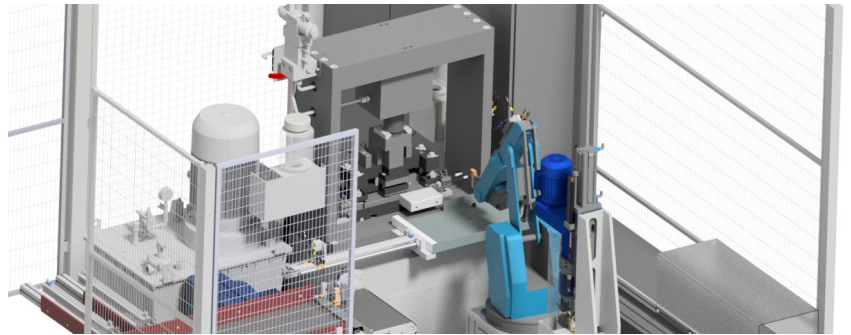

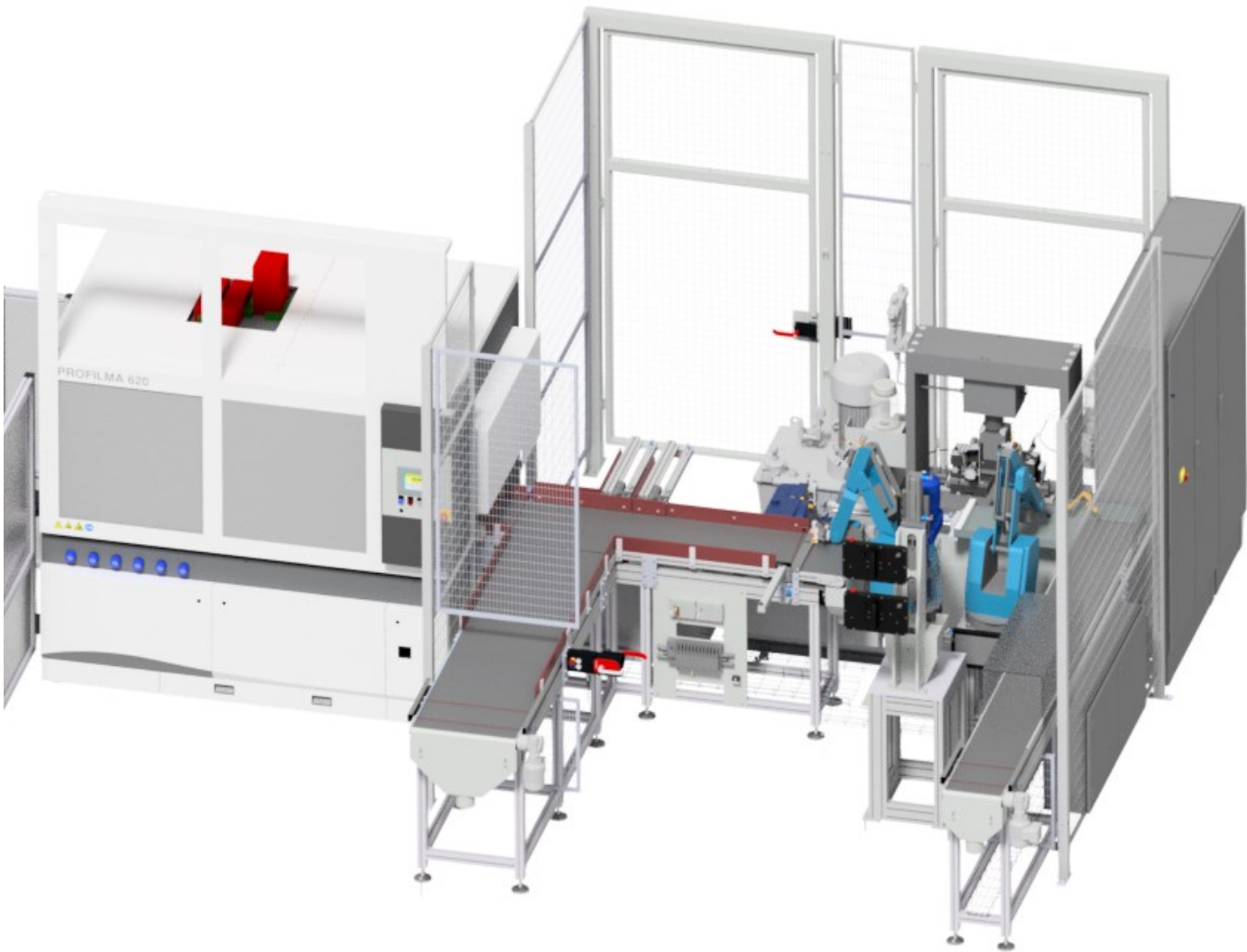
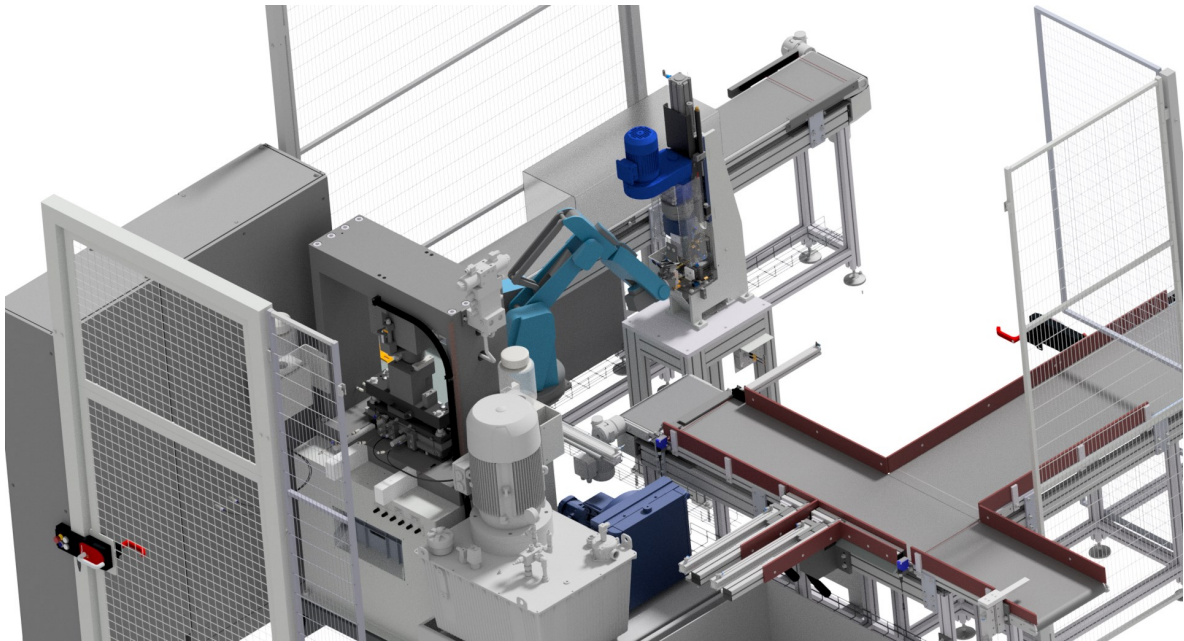

SAMPLES OF SPECIAL PURPOSE MACHINES

Profilma 460 production line with laser marking station

This cutting line contains a loading magazine with a profile recognition camera, a Profilma 460 automatic saw, linear axis outfeed pusher, trim-cut and rest piece separator, a buffer belt. At the end of the buffer belt a handover station is mounted to load the parts into an automatic brush deburring system. Afterwards a rotating picker swivels the part below a laser marking station, followed by an identical picker to rotate the part under an verification station,





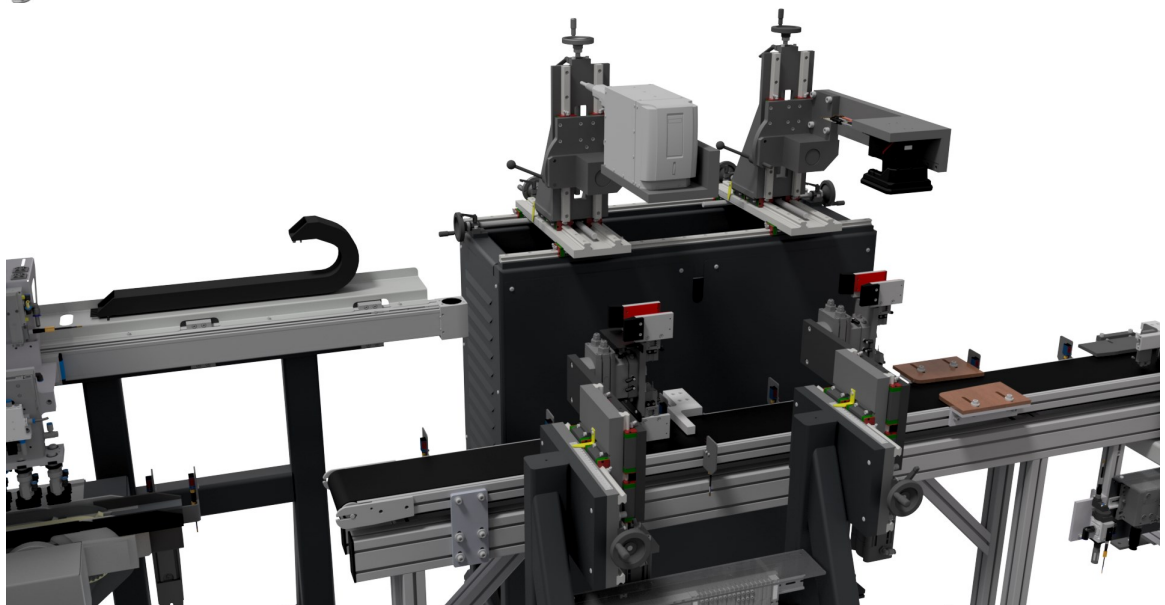
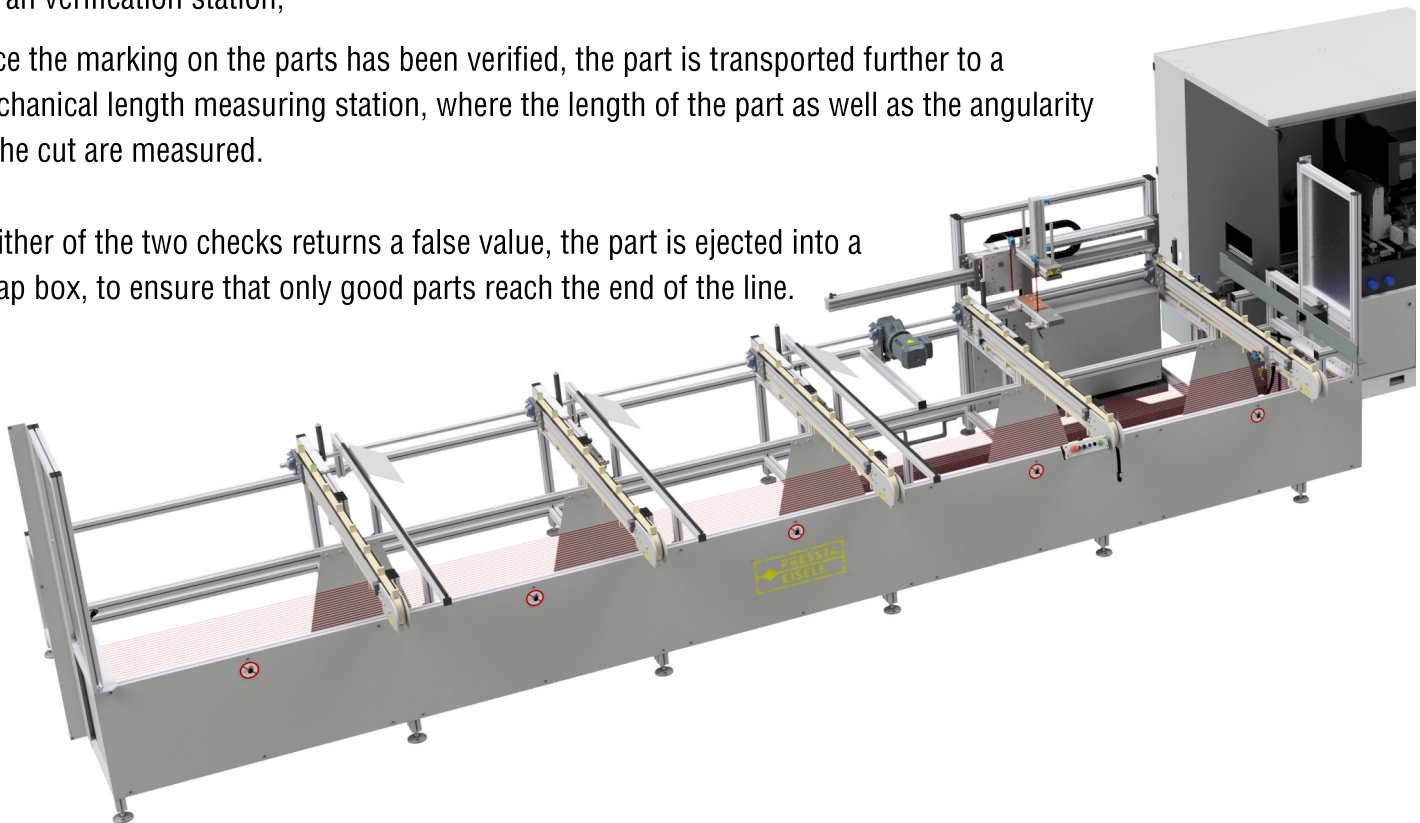

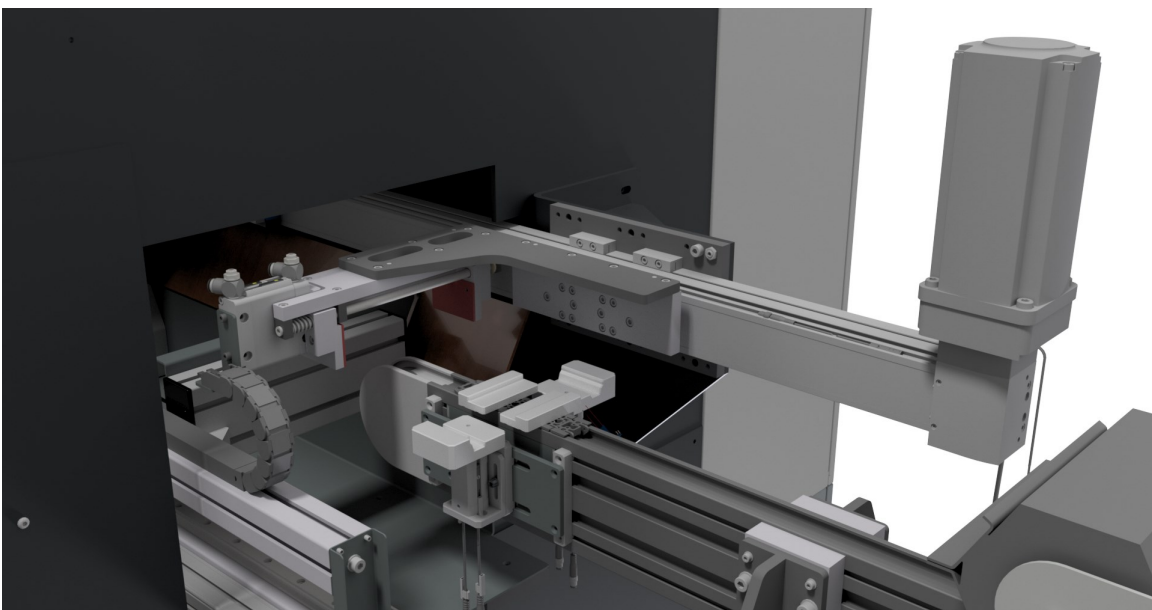
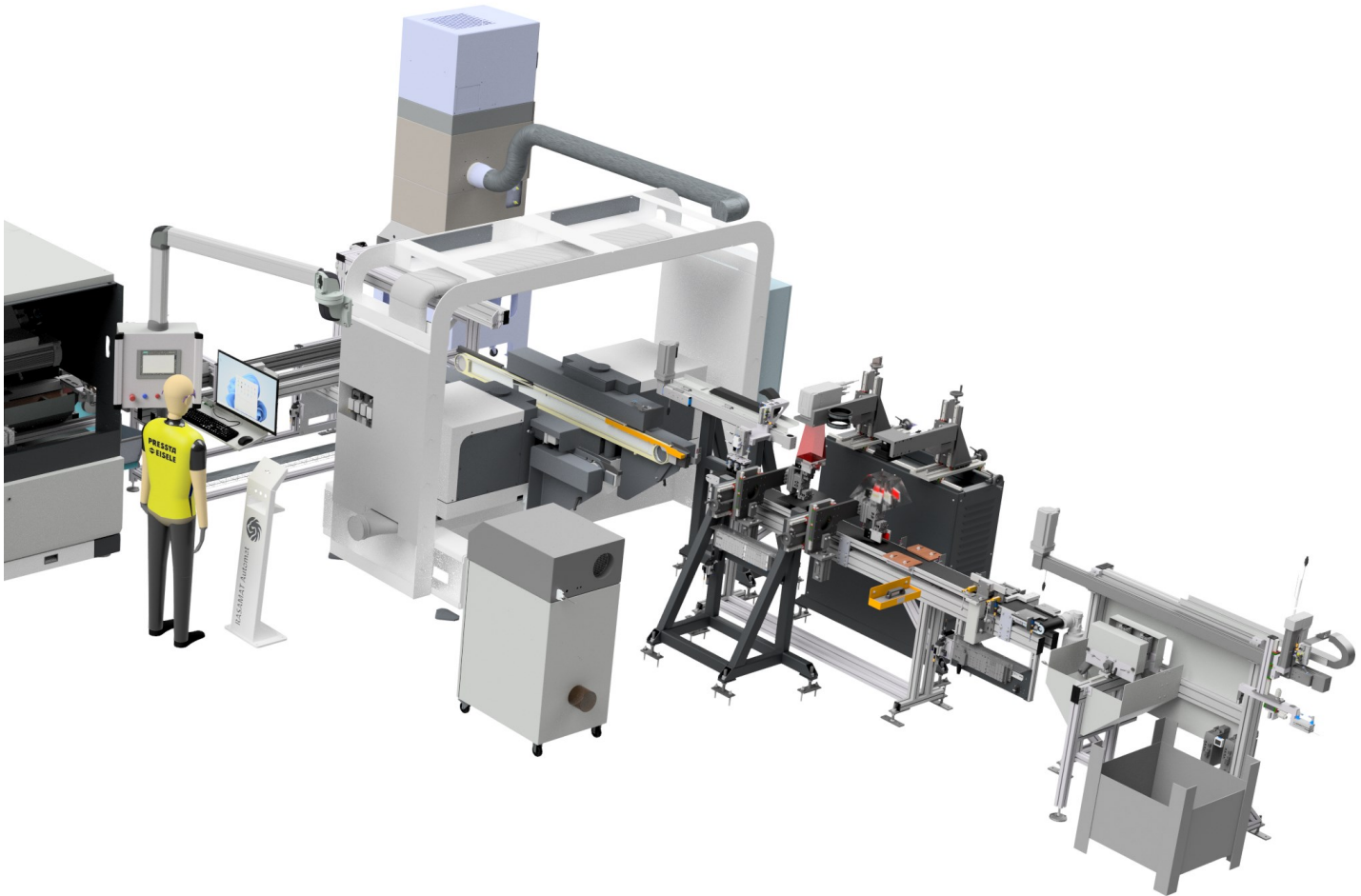
Once the marking on the parts has been verified, the part is transported further to a mechanical length measuring station, where the length of the part as well as the angularity of the cut are measured.





If either of the two checks returns a false value, the part is ejected into a scrap box, to ensure that only good parts reach the end of the line.





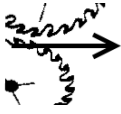

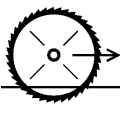
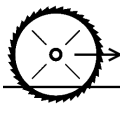

Overview cutting solutions



Machine name	TS350	GS350	GS600	GS800	GS550 Fix	GS700 Fix
Machine type	transportable manual saw	(semi) manual saw	semi-manual saw	semi-manual saw	semi-manual saw	semi-manual saw
Motor power	1.5 kW	2.2 kW	5.5 kW	7.5 kW	7.5 kW	10 kW
max cutting height	90 / 115 mm (45°)	125 mm	225 mm	320 mm	190 mm	270 mm
max. cutting width	160 / 115 mm (45°)	175 mm	300 mm	450 mm	350 mm	530 mm
min. / max. cut-off length	NA (manual material feed)	NA (manual material feed)	NA (manual material feed)	NA (manual material feed)	NA (manual material feed)	NA (manual material feed or pusher)
Main usage area	construcion sites	small metal worker	metal worker	larger metal worker	industry	industry
Type of cutting	vertical 90° saw table tiltable 45° - 90° - 45°	vertical 90° saw table tiltable 30° - 90° - 0°	vertical 90° saw table tiltable 20° - 90° - 20°	vertical 90° saw table tiltable 22.5° - 90° - 22.5°	vertical 90°	vertical 90°
Blade stroke						
Saw blade Ø	350 mm	350 mm	600 mm	800 mm	550 mm	700 mm
Material feeder type	manual	manual	manual	manual	manual or pusher	manual or pusher
Material feeder length	NA	NA	NA	NA	NA	NA
Dimension (w x d x h) in cm	ca. 78 x 48 x 87	ca. 75 x 90 x 145	ca. 125 x 135 x 165	ca. 150 x 155 x 195	ca. 115 x 145 x 145	ca. 135 x 140 x
Weight	80 kg	180 kg	550 kg	980 kg	480 kg	1250 kg
Accessories						
Extraction unit	✗	MG3	MG3	MG3	MG3	MG3 / MG9VA
Roller conveyor	✓	✓	✓	✓	✓	✓
Length measuring unit	✓	✓	✓	✓	✓	✓
Outfeed conveyor (trim-cut / rest-piece separator)	✗	✗	✗	✗	✗	✗
Outfeed table / shaker table	✗	✓	✓	✓	✓	✓
Outfeed table motorized	✗	✗	✗	✗	✗	✗
Loading magazine	✗	✗	✗	✗	✗	✗
Robotic handling	✗	✗	✗	✗	✗	✗
Marking / measuring	✗	✗	✗	✗	✗	✗

Machine name	Prisma 500	Prisma 650	PS500(65)	PS1000	Profilma 501	Profilma 502
Machine type	notching saw	automatic notching saw	manual high width saw	automatic high width saw	automatic saw	automatic saw
Motor power	2 x 3 kW	2 x 3 kW	12 (18.5*) kW	18.5 kW	7.5 kW	7.5 kW
Max cutting height	210 mm (notch)	262 mm (notch)	177 (202) mm	235 mm	140 mm	140 mm
Max. cutting width	185 mm (notch)	210 mm (notch)	500 (470) mm	1015 mm	270 mm	270 mm
Min. / max. cut-off length	NA (notching saw)	NA (notching saw)	NA (manual material feed)	10-3,250 mm	3-3,350 mm	3-4,000 mm
Main usage area	fascade / window	fascade / window	industry	industry	metal / industry	metal / industry
Type of cutting	hor. 30°-90°-30° vert. 30°-90°-30° saw table tiltable 30°-90°-30°	hor. 90°+45°-45° vert. 90°-60°+30° saw table tiltable 30°-90°-45°	vertical 90°	vertical 90°	vertical 90°	vertical 90°
Blade stroke						
Saw blade Ø	500 & 550 mm	550 & 650 mm	600 (650*)mm	600/700 mm	550 mm	550 mm
Material feeder type	fixed position	fixed position	manual	automatic, ball	automatic, ball	automatic, ball
Material feeder length	NA	NA	NA	650 mm	670 mm	800 mm
Dimension (w x d x h) in cm		ca. 275 x 184 x 195			ca. 170 x 148 x 155	ca. 160 x 141 x 151
Weight	1150 kg	1500 kg			480 kg	1,650 kg

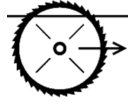
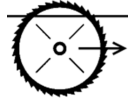
Accessories						
Extraction unit	✗	✗	MG3	MG9VA	MG3 / MG9VA	MG3 / MG9VA
Roller conveyor	✗	✗	✓	✓	✓	✓
Length measuring unit	✗	✗	✓	✓	✗	✗
Outfeed conveyor (trim-cut / rest-piece separator)	✗	✗	✗	✗	✗	✗
Outfeed table / shaker table	✗	✗	✓	✓	✗	✗
Outfeed table motorized	✗	✗	✗	✗	✗	✗
Loading magazine	✗	✗	✗	✗	✓	✓
Robotic handling	✗	✗	✗	✗	✓	✓
Marking / measuring	✗	✗	✗	✗	✗	✗

Overview cutting solutions

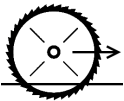
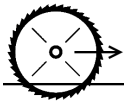
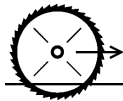
Machine name	P 502 ST-V	502 ST-HV	502 BG	540 ST	540 BG	460
Machine type	cutting-punching combination	cutting-punching combination	cutting-drilling combination	cutting-punching combination	cutting-drilling combination	automatic high performance saw
Motor power	7.5 kW	7.5 kW	7.5 kW	7.5 kW	7.5 kW	12 (18.5*) kW
max cutting height	65 mm	65 mm	140 mm	58 mm	85 mm	148 mm
max. cutting width	170 mm	135 mm	270 mm	400 mm	400 mm	250 mm
min. / max. cut-off length	3-4,000 mm	3-4,000 mm	3-4,000 mm	3-2,000 mm	3-2,000 mm	3-3350 mm
Main usage area	solar / electronic / automotive	solar / electronic / automotive	solar / electronic	solar / electronic	solar / electronic	industry / automotive
Type of cutting	vertical 90°	vertical 90°	vertical 90°	vertical 90°	vertical 90°	vertical 90°
Blade stroke						
Saw blade Ø	500/550 mm	500/550 mm	550 mm	500 mm	500 mm	(400) 460 mm
Material feeder type	automatic, ball	automatic, ball	automatic, ball	automatic, ball	automatic, ball	automatic, ball
Material feeder length	800 mm	800 mm	800 mm	400 mm	400 mm	670 mm
Dimension (w x d x h) in cm	ca. 311 x 153 x 197	ca. 311 x 153 x 197		ca. 259 x 168 x 170	ca. 241 x 179 x 210	ca. 208 x 168 x 195
Weight						2,700 kg
Accessories						
Extraction unit	MG3	MG3	MG3 / MG9VA	MG9VA	MG9VA	MG9VA
Roller conveyor	✓	✓	✓	✓	✓	✓
Length measuring unit	✗	✗	✗	✗	✗	✗
Outfeed conveyor (trim-cut / rest-piece separator)	✗	✗	✗	✗	✗	✓
Outfeed table / shaker table	✗	✗	✗	✗	✗	✓
Outfeed table motorized	✓	✓	✗	✗	✗	✓
Loading magazine	✗	✗	✗	✗	✗	✓
Robotic handling	✓	✓	✓	✓	✓	✓
Marking / measuring	✗	✗	✗	✗	✗	✓

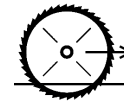
Machine name	Profilma	KS600R	KS650R	KS700R	KS800R	SW600
Machine type	automatic high performance saw	automatic high performance saw	automatic high performance saw	automatic high performance saw	automatic high performance saw	automatic cutting line
Motor power	18.5 KW	18.5 KW	18.5 KW	18.5 KW	18.5 KW	5.5 KW
max cutting height	205 mm	210 mm	235 mm	260 mm	320 mm	250 mm @90°
max. cutting width	400 mm	350 mm	470 mm	475 mm	450 mm	168 mm
min. / max. cut-off length	2-5,000 mm	10-7,200 mm	10-7,200 mm	10-7,200 mm	10-7,200 mm	90-4,000 mm
Main usage area	industry / automotive	industry / automotive	industry / automotive	industry / automotive	industry / automotive	industry / automotive
Type of cutting	vertical 90°	vertical 90°	vertical 90°	vertical 90°	vertical 90°	angled 22.5° - 157.5°
Blade stroke						
Saw blade Ø	650 mm	600 mm	650 mm	700 mm	800 mm	600 mm
Material feeder type	automatic, ball	linear pusher	linear pusher	linear pusher	linear pusher	linear pusher
Material feeder length	1020 mm	7300 mm	7300 mm	7300 mm	7300 mm	6500 mm
Dimension (w x d x h) in cm	ca. 244 x 166 x 193					
Weight	3,100 kg	variable	variable	variable	variable	variable
Accessories						
Extraction unit	MG9VA	MG9VA	MG9VA	MG9VA	MG9VA	MG9VA
Roller conveyer	✓	✗	✗	✗	✗	✗
Length measuring unit	✗	✗	✗	✗	✗	✗
Outfeed conveyer (trim-cut / rest-piece separator)	✓	integrated	integrated	integrated	integrated	integrated
Outfeed table / shaker table	✓	✓	✓	✓	✓	✓
Outfeed table motorized	✓	✓	✓	✓	✓	✓
Loading magazine	✓	integrated	integrated	integrated	integrated	integrated
Robotic handling	✓	✓	✓	✓	✓	✓
Marking / measuring	✓	✓	✓	✓	✓	✓

**PRESSTA
EISELE**



HEADQUARTER GERMANY

PRESSTA EISELE GMBH

Bergstraße 9, 56859 Bullay

Fon: +49 6542 93620

Mail: info@pressta-eisele.de



SUBSIDIARY POLAND

PRESSTA EISELE POLSKA

Ul. Zulawska 12, 82-300 Elblag

Fon: +48 55230 7960

Mail: biuro@pressta.pl



SUBSIDIARY SLOVAKIA

PRESSTA EISELE CS, S.R.O.

Ul. A. Dubceka 291, 01303 Krasnany

Fon: +42 141 5692679

Mail: pressta-eisele@pressta-eisele.eu

ALUMINIUM PROCESSING FOR ALL INDUSTRIES