



# Digital Measuring Instruments

<b>Hardness Testing .....</b>	<b>229 – 231</b>
Hardness Tester .....	229 – 230
Accessories for Hardness Tester .....	231
<b>Thickness Testing .....</b>	<b>232 – 236</b>
Thickness Gauges .....	232 – 235
Accessories for Thickness Gauges .....	236
<b>Various Digital Measuring Instruments .....</b>	<b>237 – 247</b>
Vibration Meters .....	237
Hand Tachometers and Stroboscopes .....	237 – 238
Thermometers .....	239 – 240
Surface Roughness Measuring Devices .....	240 – 242
Photo/Video Endoscopes .....	243 – 244
Other Digital Measuring Instruments .....	245 – 247
<b>Electrical Measuring Instruments .....</b>	<b>248 – 250</b>
Voltage Tester .....	248 – 249
Multimeters .....	250
<b>Weight and Force Measuring Instruments .....</b>	<b>252 – 256</b>
Scales .....	252 – 254
Dynamometers .....	254 – 256

# Image Directory • Digital Measuring Instruments

				
Page 229	Page 229	Page 230	Page 230	Page 230
				
Page 231	Page 231	Page 231	Page 231	Page 231
				
Page 231	Page 231	Page 231	Page 231	Page 231
				
Page 231	Page 231	Page 232	Page 232	Page 233
				
Page 233	Page 234	Page 234	Page 235	Page 236
				
Page 236	Page 236	Page 236	Page 236	Page 236
				
Page 236	Page 237	Page 237	Page 238	Page 238



# Image Directory • Digital Measuring Instruments

				
Page 238	Page 238	Page 238	Page 238	Page 238
				
Page 238	Page 238	Page 238	Page 239	Page 239
				
Page 239	Page 239	Page 239	Page 239	Page 239
				
Page 239	Page 240	Page 240	Page 240	Page 241
				
Page 241	Page 242	Page 242	Page 242	Page 242
				
Page 242	Page 242	Page 243	Page 244	Page 244
				
Page 245	Page 245	Page 245	Page 246	Page 246



# Image Directory • Digital Measuring Instruments







				
Page 246	Page 246	Page 247	Page 247	Page 247
				
Page 248	Page 248	Page 248	Page 249	Page 249
				
Page 250	Page 250	Page 252	Page 252	Page 252
				
Page 252	Page 253	Page 253	Page 254	Page 254
				
Page 255	Page 255	Page 255	Page 255	Page 256
				
Page 256	Page 256			

## BARCOL Impressor, Hardness Tester

- portable device, one hand use, for fast and location independent hardness testing
- with Bluetooth® data output and with software
- Applications:  
It is mainly used in aluminium processing industry, testing pure aluminium, soft aluminium, thick aluminium alloy, aluminium strip, aluminium rod, aluminium castings, aluminium forgings and aluminium alloy products. Also, it can be used for glass steel industry.  
The device is suitable for testing large and extra thick workpieces.

- rugged ABS plastic housing, with key pad, with backlight
- LCD display with clear reading, digit height 9 mm
- LED signals for the hardness scales HW, HB HV, HRB, HRE, HRF, HRH
- with function of calculation the average value, can calculate the average value of 29 sets of data at most
- with the max. hold function, recording the max. hardness value during measurements
- with good, convenient calibration and high accuracy detection
- wide test range, can test from very soft pure aluminium to a particularly hard aluminium alloy, effective test range equivalent to the Brinell Hardness 25 ~ 150 HB
- ON/OFF-button, autom. power off, average, max value, menu function
- operation temperature -0 °C ~ +50 °C, rel. humidity 20 – 80 %RH
- incl. 2x 1.5 V battery (type AAA, art.-no.: 90002)
- incl. 2 test blocks, 2 pins, pin length calibration block, screw driver, spanner, installation software for data transmitting and operation manual



ART NO	 HBa	 HBa	 Hba	 Hba	 Hba	 Hba	
650270	0 – 100	0.1	81 – 88 ± 1	42 – 48 ± 2	81 – 88 ± 1.5	42 – 48 ± 2.5	170 x 60 x 70

## Universal Digital Rebound Hardness Tester

- with integrated impact device type „D“, portable device without cable connection
- measurement is based on the principle of Leeb

- hand-held device, rugged, polyamide housing material, with self-calibration function
- LCD display with clear reading and backlight, digit height 9 mm
- autom. power off, memory with 99 data
- suitable for testing hardness of almost all Ferrous (Fe) and Non-Ferrous (NFe) materials
- direct display of hardness scales: HL, HRC, HRB, HB, HV and HS
- statistics function: average / min. / max. / value
- provides testing at any angle, even upside down
- min. workpiece weight 2 ~ 5 kg on a solid ground, at 0.05 ~ 2 kg with couplant paste
- for indentation depth see techn. data of the impact devices on page 309
- min. radius workpiece (concave/convex) Rmin. = 50 mm, with support ring Rmin. = 10 mm
- min. surface roughness of workpiece 1.6 µm (Ra)
- storage temperature -20 °C ~ 70 °C, operation temperature -10 °C ~ 45 °C
- incl. cleaning brush, test block with HLD value and with calibration certificate
- incl. 1x 9 V battery (type 6LR61, art.-no.: 90006) and operation manual



ART NO		 (HL=800 / ±0.2 HRC)		
651609	200 – 960 HL / 19 – 68 HRC 13 – 101.7 HRB / 20 – 655 HB 80 – 940 HV / 32 – 99.5 HS	±0.6 %	100 x 60 x 33	inkusive

# Hardness Testers

## Universal Digital Rebound Hardness Tester

- portable device for quick and location-independent hardness tests, based on the Leeb principle
- with external impact device type „D“ (standard)
- with USB data output and Dataview software

- rugged, anodized aluminium housing, with key pad
- multifunction display with clear reading, with switchable backlight
- display functions: hardness scales, hardness value, date, testing time, battery indicator, impact direction, average value, recognition of impact device, memory capacity for 600 groups
- suitable for most metallic materials, measuring in any position, vertical, horizontal and upside down
- ON/OFF switch or autom. power off
- incl. Adjusting limit function, autom. alarm function when exceeding the limit value
- min. workpiece weight 2 kg on solid support
- direct display of hardness scale in HL, with autom. conversion in HRB, HRC, HV, HB, HS
- and tensile strength (U.T.S.)
- min. workpiece radius (concave/convex)  $R_{min} = 30 \text{ mm}$  ( $< 30 \text{ mm}$  with support ring, incl. in the set)
- operation temperature  $-20 \text{ }^\circ\text{C} \sim +60 \text{ }^\circ\text{C}$ , rel. humidity 20 – 90 % RH
- incl. 2x 1.5 V Battery (type AA, art. no.: 90003)
- incl. test block type „D“ (2 parts) and impact device type „D“, more impact devices are available as accessories
- with brush, USB data cable, screw driver, data view software, workshop calibration certificate and operation manual

art. no. 651608 with additional functions:

- anti-slip soft shell housing
- integrated thermal printer for direct printing of all values and histogram
- with rechargeable Li-ion battery and charger 100 – 240 V/AC



ART No 651617

ART No 651608

				DIN ISO	ASTM	BS	CE	CC
				DIN ISO	ASTM	BS	CE	CC

ART No	at least workpiece thickness mm	max. hardness of workpiece HLD	max. HLD	mm	
651617	impact device type D/DC/DLD/D+15 = 5 mm impact device type C = 1 mm impact device type G = 10 mm	960	±6	130 x 70 x 30	inclusive
651608	impact device type D/DC/DLD/D+15 = 5 mm impact device type C = 1 mm impact device type G = 10 mm	960	±6	230 x 86 x 46	inclusive

## Shore Hardness Tester „Durometer“ • analog model

- portable device for measuring the hardness for elastomers and plastics
- Shore „A“: rubber, elastomers, neoprene rubber, silicon, vinyl, soft plastics, leather, felt and similar materials
- Shore „D“: plastic, formica, plexiglass, epoxies and similar materials

- rugged metal housing, compact design
- with drag pointer, with needle protection
- 2 different models, for Shore „A“ and Shore „D“ measurements
- measuring needle made of special steel, needle guidance is linear mounted
- incl. test block, with operation manual



DIN ASTM

ART No	shore type	max. spring load N	mm		needle ° / mm	meas.-face mm	indenter type	mm
650720	A	8.064	0 – 100 HA	1	35.00 / $\varnothing$ 0.90	$\varnothing$ 18	blunt taper	100 x 64 x 35
650721	D	44.54	0 – 100 HD	1	30.00 / R 0.10	$\varnothing$ 18	sharp point	100 x 64 x 35



## Impact Devices for Special Applications

- suitable for our hardness testers



**reference**  
 impact body „G“ suitable for impact device „G“  
 impact body „D“ for all other impact devices

ART No	suitable for version	article description	application
659892	type "D"	impact device "D"	standard impact device. for the majority of hardness testing assignments
659893	type "C"	impact device "C"	device with reduced energy (~¼ of that for type D), thin walled or impact sensitive components
659894	type "DC"	impact device "DC"	extremely short impact device
659895	type "D+15"	impact device "D+15"	impact device with particularly slim front section and with measuring coil moved back
659896	type "DL"	impact device "DL"	tube front section diameter ø 4.20 mm, length 50.00 mm
659897	type "G"	impact device "G"	enlarged test tip, increased impact energy (~9 x that of type D), with only minor damage to the surface
659890	type "D"	impact body "D"	for measurements in the extremely high hardness range up to 500 HRC/650 HV. Tool steel with high carbide content inclusions for measurements up to 1200 HV
659891	type "G"	impact body "G"	for measurements in the extremely high hardness range up to 500 HRC/650 HV. Tool steel with high carbide content inclusions for measurements up to 1200 HV
659893-2	type "C"	impact body "D"	for surface hardened elements, coatings, thinly coated or impact sensitive parts
659894-2	type "DC"	impact body "D"	for standard measurements in holes, cylinders, inside measurements, etc.
659895-2	type "D+15"	impact body "D"	for general measurements in narrow grooves and on narrow surfaces ( e.g. gears )
659896-2	type "DL"	impact body "D"	for measurements in inaccessible places and recesses
651690	all models	support rings with holder, set of 11-pcs.	on curved surfaces with a radius under 30 mm, effective positioning, rings can be screwed on front of the impact device
651698-2	651698-1	printer cable	—
651698-3	651606	data cable USB to PC and RS232C	—
651692-1	all models with data output	software for data process	data view/statistics
651699	all models	cable with Lemo connector	replacement cable for impact device
659899	all "D" versions	test block "D", with application of HLD value	for performance tests of hardness testers
659899-2	all "D" versions	test block "D", with application of HRC value	for performance tests of hardness testers
659913	651607 + 651608	paper roll	—



# Thickness Gauges

## Universal Coating Thickness Gauge

Accessories  
on page 236

- professional, handheld measuring device for quick and flexible coating thickness measurements
- combined system with 2 probes, for iron/steel (Fe) and non-ferrous metal (Nf)
- large display, with backlight (switchable), with memory function
- rugged extruded aluminium case, USB data output and with dataview software
- operates in any position (horizontal, vertical and upside down)
- for measurements of non-magnetic layers on metal surfaces (Fe) and measurements of insulating layers on non-ferrous metals (Nf)
- application fields include surface engineering, automotive industry, electroplating, pipeline construction, aluminium industry, spray coating, plastic coating, mechanical engineering, bridge construction, etc.
- rugged extruded aluminium body frame, with soft key pad
- multi-function display with clear reading, with backlight switchable
- with „low-battery“ indicator, autom. recognition of probe type, alarm function switchable
- magnetic induction measuring principle (Fe) and eddy current measuring principle (Nf)
- units in  $\mu\text{m}$  or mils, autom. substrate recognition, manual or autom. shut down function
- two measuring methods: continuous measurement and a single measurement
- 3 calibration methods: one point calibration, two point calibration and calibration with a roughened surface
- 5 calibration foil-set, 1 x aluminium substrate block and 1 x iron substrate block
- 5 statistical values: mean value, max. value, min. value, standard deviation and numbers of measurements, storage of 500 measuring data in total
- min. radius of workpiece: convex 5 mm, concave 50 mm
- min. substrate thickness Fe (F1)-probe 0.75 mm, for Nf (N1)-probe 50  $\mu\text{m}$
- direct printing of the measured values by USB cable to PC or printer
- operating temperature  $-0\text{ }^{\circ}\text{C} \sim 40\text{ }^{\circ}\text{C}$ , rel. humidity 20 – 90 %RH
- inclusive 2x 1.5 V battery (type AA, art.-no.: 90003), with screw driver, data cable, dataview software, operation manual



ART NO	$\mu\text{m}$	$\mu\text{m}$ F1 + N1	$\mu\text{m}$ probe F1	$\mu\text{m}$ probe N1	mm
480227	0.10 / 0.10	0 - 1250	1 + 3 %	1.50 + 3.00 %	115 x 70 x 30

## Universal Paint Thickness Gauge • IP52

- professional, handheld device for quick and accurate paint thickness measurements
- device with built-in probe for quick, non-destructive and accurate measurements
- integrated probe for measurements on smooth, painted areas
- combined system for measurements on iron/steel (Fe) and non-ferrous metal (Nf) both of these offer the highest degree of precision even with thinnest paint coatings
- large display, 4 digits, alphanumeric, height 8 mm
- in a rugged ABS plastic housing, with rubber protective cover
- easy single key operation, just switch on and measure, autom. base material recognition
- for measurements on level or slightly curved surfaces
- no calibration necessary, calibrated before delivery
- area of application: painting companies, spray- and powder coating, automotive companies, experts and automotive garages, oldtimer scene, machinery, aluminium industry, etc.



Anwendungsbeispiel

- rugged ABS plastic housing, with rubber protective cover, with key pad
- innovative and user friendly handling: switch on and measure
- multi-function LCD display with clear reading, autom. recognition of base material
- large contact area for reliable positioning
- magnetic induction measuring principle (Fe) and eddy current measuring principle (Nf) reading in  $\mu\text{m}$  and mil
- calibration-free measuring, acoustic signal when recording measured values
- control foil and zero-standards (1 x aluminium- and 1 x steel plate)
- min. radius workpiece for convex surfaces 25 mm, for concave surfaces 50 mm
- min. thickness of workpiece — F 0.75 mm, min. thickness of workpiece — N 0.25 mm, min. measuring surface 40 x 40 mm
- operating temperature  $0\text{ }^{\circ}\text{C} \sim 60\text{ }^{\circ}\text{C}$ , rel. humidity 20 – 90%RH, surface temperature  $-15\text{ }^{\circ}\text{C} \sim 60\text{ }^{\circ}\text{C}$
- incl. 2x 1.5 V battery (type AAA, art.-no.: 90002)
- with operation manual

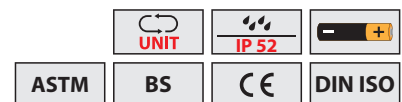

ART NO	$\mu\text{m}$	$\mu\text{m}$ Fe	$\mu\text{m}$ Nf	$\mu\text{m}$ $\pm \mu\text{m}$	mm probe	mm
480238	1.0 / 2.0 / 5.0	0 – 3000	0 – 3000	3 + 5 %	integrated	110 x 50 x 25

## Universal Coating Thickness Gauge • IP52

- professional, handheld device for quick and flexible coating thickness measurements
- device available with built-in probe or with external probe for flexible measurements
- combined system for measurements of non-magnetic layers on metal surfaces (Fe) and for measurements of insulating layers on non-ferrous metals (NFe)
- large display, 4 digits, alphanumeric, height 10 mm
- no calibration necessary, calibrated before delivery
- highly wear-resistant measuring pole made of tungsten carbide
- in a rugged ABS plastic housing, with rubber protective cover
- operates in any position (horizontal, vertical and upside down)
- application fields: painting companies, spray- and powder coating, automotive experts and automotive garages, steel- and automotive companies and shipbuilding, machinery, electro plating, aluminium industry, in laboratories, quality control, etc.
- rugged ABS plastic housing, with rubber protective cover, with key pad
- innovative and user friendly handling: switch on and measure
- multi-function LCD display with clear reading, autom. recognition of base material
- plastic base of the probes are shaped with a V-groove, thus ensuring vertical positioning on flat, cylindrical or curved surfaces
- magnetic induction measuring principle (Fe) and eddy current measuring principle (NFe) reading in  $\mu\text{m}$  and mils
- calibration-free measurements, online statistics (mean values, standard deviations, min, max)
- acoustic signal when recording measured values
- control foil and zero-standards (1x aluminium- and 1x steel plate)
- min. radius workpiece for convex surfaces 5 mm, for concave surfaces 50 mm
- min. thickness of workpiece for Fe probe 0.5 mm, for NFe probe 50  $\mu\text{m}$ , min. measuring surface 10 x 10 mm
- operating temperature 0 °C ~ 60 °C, rel. humidity 20 – 90 %RH, surface temperature -15 °C ~ 60 °C
- incl. 2x 1.5 V battery (type AAA, art.-no.: 90002)
- with operation manual and wrist strap



application example



ART No	$\mu\text{m}$	$\mu\text{m}$ Fe	$\mu\text{m}$ NFe	$\pm \mu\text{m}$	mm probe	mm
480236	1.0 / 2.0 / 5.0	0 – 3500	0 – 3000	2 or 2 %	built-in	110 x 50 x 25
480237	1.0 / 2.0 / 5.0	0 – 3500	0 – 3000	2 or 2 %	$\varnothing$ 24 x 45	110 x 50 x 25

## Ultrasonic Thickness Gauge

- Top-model, for various materials, such as steel, stainless steel, glass, gold, silver, non-ferrous metals, nylon, polyethylene, polystyrene, teflon, rubber, plexiglass, titanium, platinum, neoprene, a.m.o.
- pocket size instrument, for quick and flexible wall thickness measurements
- operates in any position (horizontal, vertical and upside down)
- easy to operate device, with automatic probe zero calibration
- rugged polyamid plastic housing, automatic probe identify system
- with touchscreen soft key pad, with low-high limit setting and alarm signal
- resolution in 0,01 mm/0.001" or 0,1 mm/0.01", measurements 4/s and 10/s in „fast mode“
- fast calibration on integrated 4 mm test plate ( $\varnothing$  15 mm)
- 4-digit LCD-display with clear reading and backlight display for dark environment
- incl. interchangeable 5 MHz standard transducer (< 60 °C) with  $\varnothing$  10 mm, for general purpose
- operating temperature -20 °C ~ +50 °C, measuring temperatur -20 °C ~ 350 °C (acc. to the probes)
- with average calculation of max. 9 readings, memory of 5.000 reading with location number
- with „low battery“ indicator, autom. power off selectable, measuring unit in mm/inch swichtable
- with selectable sound velocity range from up 1.000 m/s ~ 9.999 m/s
- with installation software on CD-Rom
- with USB data output to PC
- with 2x 1.5 V battery (type AAA, art.-no.: 609283), couplant, hand strap, operation manual
- incl. workshop calibration certificate, in sturdy plastic case



Accessories on page 236

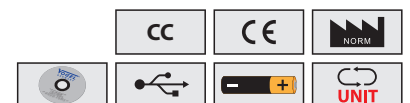
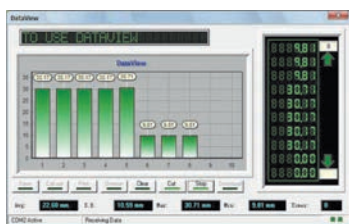

ART No	mm / inch	mm / inch	% +0.1	mm	CC
480101	0.65 – 400 mm / 0.026 – 15.7"	0.1/0.01 mm / 0.01/0.001"	0.5 % +0.1	116 x 64 x 24	inclusive

# Thickness Gauges

## Ultrasonic Thickness Gauge

- compact handheld measuring device for quick and location independent measuring
- with 2 external probes
- dedicated for many materials, such as steel, cast iron, nodular cast iron, aluminium, bronze, copper, zinc, etc., ceramic, glass, composites, epoxies, homogenously plastics, other ultrasonic wave well conductive materials
- large LCD display, 4-digit, in a rugged ABS plastic housing
- operates in any position (horizontal, vertical and upside down)
- with integrated steel test plate for fast calibration
- areas of application e. g.: surface technology, automotive-, metal-, machinery- and aluminium-industry, storage tanks, pressure boiler, shipbuilding, bridge construction corrosion tests, etc.

- rugged ABS plastic housing, with soft keypad
- multi-function display with clear reading, mm/inch switchable
- ON/OFF button, coupling state indication, memory function for 2000 groups
- Pre-Set function for upper and lower limit setting
- incl. software for data transmission
- with 2 external probes:
  - 1x N05/90° angle probe (ø 10 mm/5 MHz), for steel 1 – 250 mm
  - 1x N07 (ø 6mm/7MHz), for thin-walled pipes or small radii 0.75 – 50.00 mm
- operating temperature -10 °C ~ 60 °C, rel. humidity 20 % ~ 90 % RH
- incl. 2x 1.5 V battery (type AA, art. no.: 90003), couplant, operation manual

Accessories on page 236

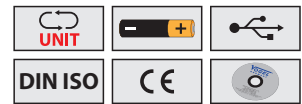
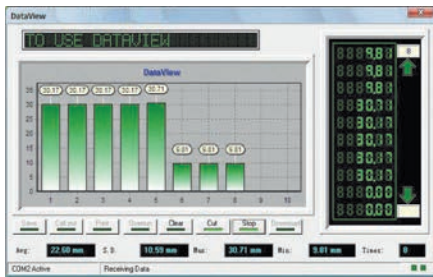

<b>ART N°</b>	mm	mm N05	mm N07	sound velocity m/s	max.	mm
480261	0.01	1 – 250	0.75 – 50.00	1000 – 9999	± 0.50 % + 0.01 mm	163 x 78 x 33

## Ultrasonic Thickness Gauge

- designed to measure the thickness of ferrous (Fe) or non-ferrous materials (NFe)
- dedicated for many materials, such as steel, cast iron, grey cast iron, nodular cast iron, aluminium, copper, bronze, zinc, glass (quarz), ceramics, composites, epoxies, homogenously plastics and other ultrasonic wave well conductive materials
- rugged handheld measurement device, for quick and flexible wall thickness measurements
- suitable for most metallic and non-metallic ultrasonic wave can go through, application areas are e.g. surface technology, automotive industry, storage tank, pressure boiler, shipbuilding, chemical- and petrol plants, power stations, aluminium industry, machine engineering, bridge construction, etc.
- for wall thickness checking of pressure tanks, vessels, oil tanks, chemical instruments and many others
- operates in any position: horizontal, vertical or upside down

- robust housing made of polyamide, with soft keypad
- 4-digit LCD display, with backlight, digit height 9 mm
- with integrated test block for fast calibration
- autom. calibration function, reading in mm/inch
- On/Off key and autom. power off function, with „low-battery“ indicator
- selectable sound velocity 1000 – 9999 m/s
- internal data memory for 40 measurements
- incl. exchangeable 5 MHz transducer, ø 10 mm, for standard purposes
- operation temperature 0 °C ~ +40 °C, humidity 20 % – 90 % RH
- incl. 2x battery 1.5 V (type AA, art. no.: 90003), with operation manual, wrist strap and couplant

Accessories on page 236



<b>ART N°</b>	mm	mm / inch	max.	mm
480120	0.01	0.70 – 300.00 / 0.36 – 11.80	0.50 % + 0.10	124 x 67 x 30





## Ultrasonic Thickness Gauge with Echo-Echo System (A+B-Scan)

- top class device, with USB data output, with A- + B-Scan-Mode
- suitable for measuring material thickness, also through coated surfaces
- location-independent material measurement with simple operation
- dedicated for ferrous (Fe) and non-ferrous materials (NFe)
- large TFT color display (320 x 240 mm), with clear reading
- multilingual menu navigation, data transfer by USB output to PC in any windows system
- 2 – 9 average measurements, operates in any position: horizontal, vertical or upside down
- Min/Max limit setting, with alarm function, low battery indicator
- automatic probe recognition and automatic zero calibration
- integrated test plate for fast calibration
- automatic measurement and manual-measurement selectable
- automatically locates the detection point
- measurement screen is automatic frozen, which makes it easy to analyze the data for the user
- with our optional available probes our device is dedicated for materials e.g. such as: steel, cast iron, grey cast iron, nodular cast iron, aluminium, copper, brass, zinc, glass (quartz), composites, ceramic, epoxies, PVC, homogeneously plastics and other ultrasonic wave well conductive materials
- rugged housing, with soft key pad
- TFT color display, with multi-function indicator, clear reading
- integrated steel test plate for fast calibration
- autom. calibration function, values in mm/inch
- On/Off key, autom. power off, with „low-battery“ indicator
- selectable sound velocity range 1.000 m/s – 9.999 m/s
- with data memory 100 measurement in 100 different files
- incl. exchangeable 5 MHz probe,  $\varnothing$  13,20 mm, < 60 °C, for standard purpose
- operation temperature -20 °C ~ +50 °C, rel. humidity 20 – 90 % RH
- incl. 2x 1,5 V battery (type AA, art. no.: 90003),
- with couplant, workshop calibration certificate and operation manual

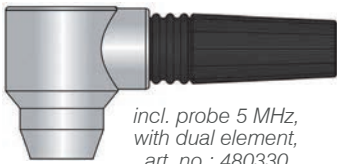

Accessories on page 236

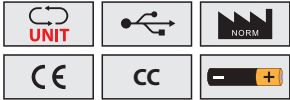

ART No	mm	mm / inch	sound velocity m/s	max.	mm	CC
480130	T-E 0.65 ~ 400.00 E-E: 3 ~ 25	0.01 / 0.001	1000 ~ 9999	±0.40 mm up to < 9.99 mm ±0.10 % + 0.04 mm up to 10.00 – 99.90 mm ±0.30 % up to > 100.00 mm	133 x 75 x 29	inclusive

Explore our **Website.**

[www.vogel-germany.de](http://www.vogel-germany.de)

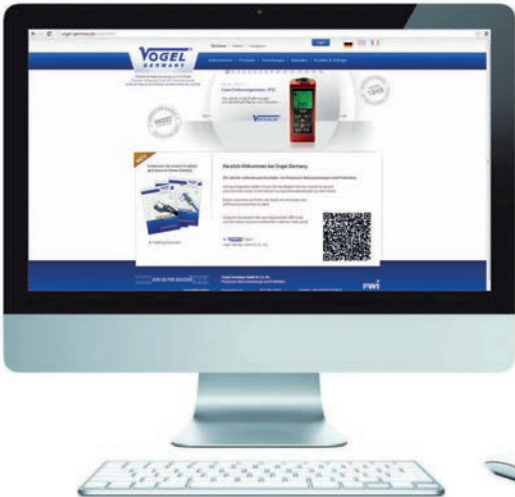

Any questions?

We are pleased to advise.

# Accessories for Thickness Gauges

## Accessories for Universal Coating Thickness Gauges

ART N°	suitable for model	application	article description	 µm
480310	all models	for calibration purpose	calibration foil set Fe + Ne	—
480315	480227	magnetic induction	probe F1 (Fe)	0 – 1250
480316		eddy current method	probe N1 (Ne)	0 – 1250
480322	480237	combined Fe + FNe	combined probe F (Fe) + N (NFe)	0 – 3500 0 – 3000
480323		magnetic induction	probe F10 (Fe)	0 – 10000



## Accessories for Ultrasonic Thickness Gauges

ART N°	suitable for model	application	article description	 mm
480280	all models	for coupling	couplant, 60 ml	—
480288			couplant, 100 ml	
480275	480120	for standard purposes	probe, ø 10 mm 5 MHz	1,00 – 250,00
480274		for thin pipes	probe, ø 7 mm 5 MHz	0,80 – 30,00
480277		for extrem high temperatures	probe, ø 12 mm 5 MHz	3,00 – 100,00
480278		for cast iron	probe, ø 12 mm 2.50 MHz	3,00 – 250,00
480330	480130	for standard purposes and for Echo-Echo up to ø 25.0 x 3.0 mm	probe ø 13.20 mm 5 MHz (< 60 °C)	T-E: 1,44-200 E-E: 3-25
480331	480101 and 480130	for thin pipes up to ø 25.0 x 1.2 mm	probe ø 11 mm 5 MHz (60 °C)	0,80 – 300,00
480332		for extrem high temperatures up to ø 25 x 2 mm	probe ø 15 mm 5 MHz, up to 350°C	2,00 – 200,00
480333		for thin pipes up to ø 15 x 1.2 mm	probe ø 9 mm 7.50 MHz (60 °C)	0,65 – 50,00
480334		for extrem thin pipes up to ø 15.0 x 1.0 mm	probe ø 6.0 mm 10 MHz (60 °C)	0,65 – 20,00
480335		for pipes up to ø 40.0 x 3.0 mm	probe ø 17 mm 2 MHz (60 °C)	2,00 – 400,00
480336	480130	for fiberglass and composites	probe ø 26 mm 1 MHz (60 °C)	3,00 – 200,00
480337	480131	for fiberglass and composites	probe ø 28 mm 1 MHz (60 °C)	20,00 – 590,00
480338	480132	for thin, curved surfaces	probe ø 7.50 mm 5 MHz (60 °C)	E-E: 0,200-10 T-E: 1,500-20
480341	480261	for standard purpose	probe ø 10 mm 5 MHz (60 °C)	1,00 – 250,00
480342		for thin, curved surfaces	probe ø 6 mm 7 MHz (60 °C)	0,75 – 50,00
480343		for cast iron and rough surfaces	probe ø 22 mm 2 MHz (60 °C)	2,50 – 350,00
480344		for extrem high temperatures	probe ø 14 mm 5 MHz, until 500 °C	2,00 – 100,00
489871	all models	6-step test block 1 / 3 / 5 / 10 / 15 / 20 mm		1,00 – 20,00
489872		4-step test block 1.50 / 4.00 / 10.00 / 18.00 mm		1,00 – 10,00

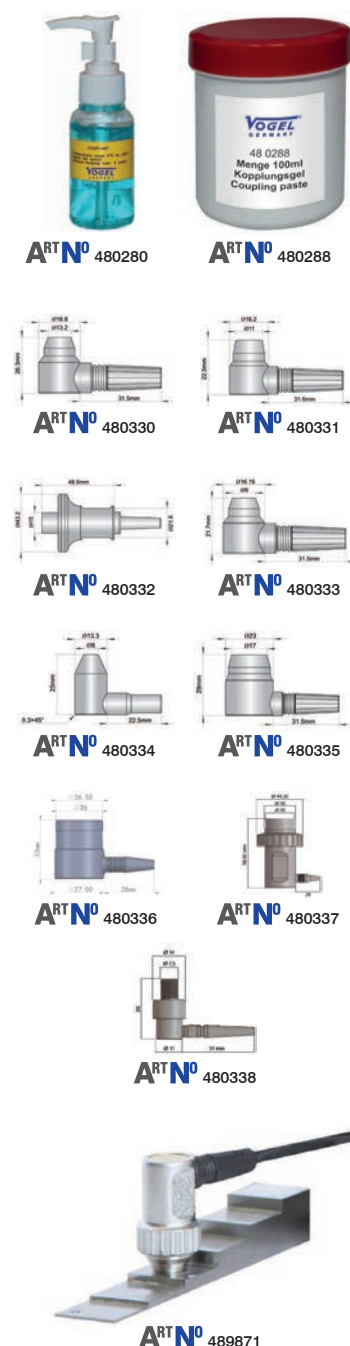





## Electr. Digital Vibration Meter

- with integrated or with external probe, incl. workshop test certificate
- compact analyser for predictive maintenance of production machinery and for a quick checking of unbalance, misalignment, bearings and gears etc.

- two-row LCD display, for velocity and temperature, digit height 15 mm/10 mm
- accuracy  $\pm 5\%$  of display value ( $\pm 2$  digits)
- with external accelerometer and adapter cable
- HOLD function for holding the determined measured value
- with magnet
- with temperature measurement (C°/F°) within range  $-10\text{ °C} \sim +80\text{ °C}$ , accuracy  $\pm 2\text{ °C}$
- rugged, polyamid plastic housing, with keypad
- large LCD display with clear reading, with backlight
- On-switch, automatic power-Off after approx. 1 min., with battery indicator
- low frequency mode "Lo-RMS" to test low vibrations
- high frequency mode "Hi-AVE" to test average acceleration
- displacement peak to peak mode "Hi-Peak"
- large frequency range: 10 Hz up to 1 kHz (Lo), 1 kHz up to 15 kHz (Hi)
- incl. 2 exchangeable probe tips, for different measuring functions:
  - short probe tip for standard vibration measurements
  - long, small probe tip for vibration measurements on small or narrow objects, etc.
  - without probe tip for vibration measurements on smooth object surfaces, etc.
- operation temperature  $0\text{ °C} \sim +40\text{ °C}$ , humidity 30 – 90 %RH  
incl. 1x 9 V battery (type 6LR61, art.-no.: 90006), with operation manual



ART NO	 velocity Lo-RMS	 velocity Hi-AVE	 displacement, peak to peak Hi-PEAK	
480605	0.1 – 199.9 mm/s	0.1 – 199.9 m/s <sup>2</sup>	0.001 – 1.999 mm	135 x 75 x 38

## Electr. Digital Hand Tachometer

- with LCD display for optical or mechanical speed detection

- measurement accuracy is  $\pm 0.02\%$  from the end value  $\pm 1$  digit
- 5 digit LCD display, sturdy ABS plastic housing
- direct and non-contact recording of rotation
- automatic Off-function, after 30 sec.
- automatic Min/Max/Average memory-function, recall by memory button
- mode function for different measurement units
- power supply via 2x 1.5 V battery (type AA, art. no.: 90003), or rechargeable batteries (optional)
- extensive accessories is included: Hand Tachometer, 10 reflective tags, adaptor for direct measuring 1:1, rubber tip, track wheel 0.1 m and 6 "
- incl. 2x 1.5 V battery (type AA, art. no.: 90003)
- operation manual and test certificate

### Option

- art. no. 270160-8 set of reflective tags (10 pcs.)

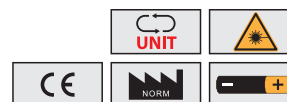

ART NO	 1 / min.	measuring distance max. mm	storage temperature °C	operation temperature °C	CC
270160	1 – 99999	600 (optically)	-20 to +70	0 to +50	on request



# Accessories for Hand Tachometers and Stroboscope

## Accessories for Electr. Digital Hand Tachometers



ART No 270160-1



ART No 270160-2



ART No 270160-3



ART No 270160-4



ART No 270160-5



ART No 270160-6



ART No 270160-7



ART No 270160-8



ART No 90003

In each set contain:

set content	270160-1	270160-2	270160-3	270160-4	0,10 m 270160-6	6" 270160-7	270160-8	90003	
270160	—	✓	✓	✓	✓	✓	✓	✓	✓
270161	✓	✓	✓	✓	✓	✓	✓	✓	✓

ART No	product description
270160-1	adapter
270160-2	extension shaft
270160-3	change attachment
270160-4	drive cone

ART No	product description
270160-5	drive tip
270160-6	measuring wheel 0.1 m
270160-7	measuring wheel 6"
270160-8	set of reflective tags, 10 pcs.

## Electr. Digital-Stroboscope • IP65

- water-, coolant proof and shock resistant hand-held device
- e.g. for use in the automotive industry and mechanical engineering
- for error analysis of high-speed industrial plants
- for optical representation of the revolutions
- in a rugged aluminium-/ABS-plastic-housing
- with modern LED technology, precise working electronic
- with auto-synchronization frequency laser function
- for non-contact measurement

- large LCD display, multiple lines, coloured lighting
- light intensity 6.500 Lux @ 300 mm, light colour approx. 6.500 K
- no wear of the high-power LEDs
- Accuracy: flash frequency (internal) and frequency measurement (external)
- resolution  $\pm 0.1$  (30 ... 999.9 FPM)  $\pm 1$  (1.000 ... 999.999 FPM)
- operation temperature 0 °C ~ 45 °C
- incl. 3x 1.5 V battery (type AA, art.-no.: 90003)
- in sturdy carrying case, with operation manual



Stroboscope on:  
rotations visible



Stroboscope off:  
rotations not visible



LED front

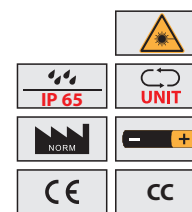

ART No			flash colour			
610102	30 ~ 999.999	0.02 % ( $\pm 1$ Digit)	white 6500 K	1 mW	191 x 82 x 60	inclusive

## Electr. Digital Thermometer

- for quick and exact measurement of temperatures
- with external temperature probe, type K
- rugged, ABS-plastic housing, with insulating peel
- large LCD display, 3 1/2 -digit, with clear reading, with battery indicator
- On/Off button, data hold button, measuring in °C and °F, max. display 1999
- 1 input for temperature probes type K, for temperature and relative measurements
- response time approx. 2.5 sec
- storage temperature 0 °C ~ +50 °C, rel. humidity < 80 % RH
- incl. 1x 9 V battery (type 6LR61, art. no.: 90006), with operation manual

### Option

- spare part temperature probe art. no. 649303



with stand



probe



bumper case



ART N°	capacity of device °C	°C	max. °C	mm
640303	-50 ~ +1300	a -50 °C ~ 200 °C	-50 °C ~ 200 °C / 200 °C ~ 1000 °C / 1000 °C ~ 1300 °C	mm
		1	±0.10 % +1.00 °C / ±0.30 % +2.00 °C / ±0.50 % +2.00 °C	147 x 71 x 34

## Temperature Probe, Type K



ART N° 649300



ART N° 649301

immersion probe

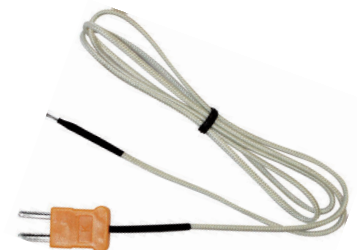

ART N° 649303



ART N° 649302

surface probe



ART N° 649304



ART N° 649305



ART N° 649306

ART N°	capacity of device °C	L mm	ø mm
649300	~ +700 °C	~ 84	3
649302	~ +400 °C	~ 150	15

ART N°	capacity of device °C	L mm	ø mm
649301	~ +700 °C	~ 150	4.00
649303	~ +400 °C	~ 950	2.00
649304	~ +400 °C	~ 15	14.92
649305	~ +600 °C	~ 150	3.50
649306	~ +800 °C	~ 170	5.00

# Thermometers and Surface Roughness Tester

## Infrared Laser Thermometer

- pistol-sized, with K-type temperature probe and shiftable laser pointer
- for quick measuring of temperatures, by temperature probe or contactless
- the devices fulfill the strict requirements of the european national guidelines

- rugged ABS plastic housing
- large LCD display with clear reading, with backlight
- temperature reading in °C / °F, with shiftable laser pointer
- autom. power off after ~ 20 sec., response time < 0.5 sec., laser protection class II
- data hold function for short memory time of the measuring value, Min/Max-function
- average value selectable, with battery indicator
- storage temperature -10 °C ~ +60 °C, operation temperature 0 °C ~ +50 °C
- relative humidity 10 – 90 % RH, emissivity adjustable
- incl. 1x 9 V battery (type 6LR61, art. no.: 90006), with operation manual

ARTN° 640314

ARTN° 640317-2

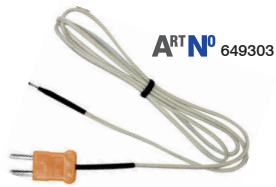

ARTN°	°C	°C	°C	°C	measuring optics	mm	ARTN° spare probe
640314	-30 ~ +550	0.1	±4 / ±4 %	±1	12:1	170 x 135 x 50	649303
640317-2	-50 ~ +1300	0.1	±2 / ±2 %	±1	16:1	170 x 135 x 50	—

## Electr. Digital Surface Roughness Tester

- portable roughness measuring device for the measurement of Rz, Ra, Rq, Rt

- robust aluminium housing, Ra, Rz, Rq, Rt roughness parameters in one gauge
- large OLED display, with switchable backlight, „low-battery“ indicator
- On/Off push button, autom. shutdown after 3 min., with beep (start-test-ready)
- measuring range selectable in  $\mu\text{m}$  /  $\mu\text{inch}$ , parameter Ra (ISO and Rz DIN)
- min. probe tips curvature radius 10 microns  $\pm 1$  microns, angle  $90^\circ +5^\circ / -10^\circ$
- different display values < 12 %, error indication  $\pm 15\%$
- force measurement: 0.016 N, force measurement share: 800 N/m
- working temperature -20 °C ~ +40 °C, rel. humidity < 90 %
- tracing length 6 mm, tracing speed 1.0 mm / sec., sensor pressure 0.5 N
- integrated sensor protection, with simple calibration function
- incl. roughness standard plate Ra, accuracy acc. ISO class 3
- with 3.7 V Li-Ion rechargeable battery, incl. charger 9 V AC
- incl. operation manual

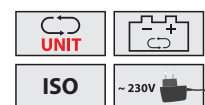

ARTN°	$\mu\text{m}$ / inch	Ra $\mu\text{m}$	Rz $\mu\text{m}$	Rq $\mu\text{m}$	Rt $\mu\text{m}$	tracing length mm	mm
657120	0.01 / 1.00	0.05 – 10.00	0.10 – 50.00	0.05 – 10.00	0.10 – 50.00	6	70 x 105 x 25



# Surface Roughness Tester

## Surface Finish Specimen „RUGOTEST“

- acc. to the norms NF E 05-501, ISO/R 468 and ISO 2632
- for testing surface roughness by sight and touch method (with finger-tip)
- available for all standard machining methods
- wear-resistant and made of stainless steel
- delivery with description

ART N° 651001

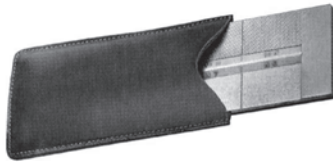
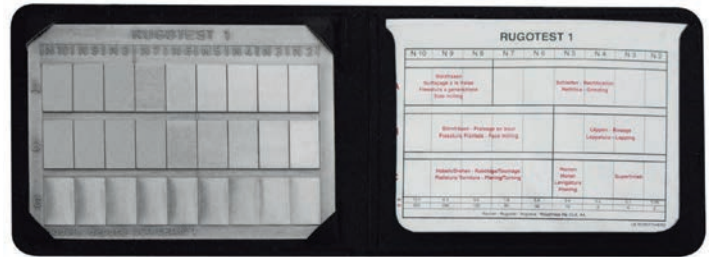

ART N° 651101 - 651107



ISO

ART N°	machining method	quantity of plates	comparaison range Ra $\mu\text{m}$	ISO class	$\rightarrow$ mm $\leftarrow$
651001	general (standard)	27	0.05 – 12.5	N2 – N10	120 x 90
651002	sand	6	0.8 – 25.0	N6 – N11	120 x 90
651003	shot / grit (coarse + fine)	18	0.0125 – 25.0	N0 – N11	120 x 90
651101	planing	6	0.8 – 25.0	N6 – N11	110 x 50
651102	turning	6	0.4 – 12.5	N5 – N10	110 x 50
651103	face milling	6	0.4 – 12.5	N5 – N10	110 x 50
651104	surface grinding	8	0.025 – 3.2	N1 – N8	130 x 50
651105	cylindrical grinding	8	0.025 – 3.2	N1 – N8	130 x 50
651107	spark erosion	6	0.4 – 12.5	N5 – N10	110 x 50

## Follow us on Facebook.

Never miss any news about our products, promotions and offers.



Any questions?  
We are pleased to advise.

[facebook.com/VogelGermany](https://facebook.com/VogelGermany)

# Surface Roughness Measuring Devices

## Electr. Digital Surface Roughness Tester

- high performance device, for professional demand
- for measurement of roughness parameters
- $R_z$ ,  $R_a$ ,  $R_q$ ,  $R_y$ ,  $R_t$ ,  $R_v$ ,  $R_{3z}$ ,  $R_{3y}$ ,  $R_{zJIS}$ ,  $R_{sk}$ ,  $R_{ku}$ ,  $R_{sm}$ ,  $R_{mr}$  with USB 2.0 data output
- rugged ABS plastic housing, in ergonomic design
- large OLED display with clear reading and with backlight
- comprehensive information and graphic representations
- diamond tracer tip, 90°, radius 5  $\mu\text{m}$ , contact power 4 mN (0.4 gf)
- standard acc. to ISO, DIN, ANSI, JIS
- digital filter RC, PCRC, Gauss, D-T13565, data memory 2 MB + 2 GB
- with built-in and rechargeable Li-Ion battery, charger 100 – 240 V / 50/60 Hz
- up to 10 hrs. permanent use, with calendar and RTC
- On/Off button, autom. power off, battery indicator
- selectable languages: english, german, chinese
- reliable software for the electrical motor drive
- connection to PC or printer, incl. interface cable
- incl. software, ground plate, calibration test block, standard tracer (art. no.: 657210), with operation manual



extensive information and graphic representations

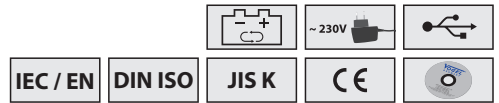

ART N°	$R_a$ / $R_q$ $\mu\text{m}$	$R_q/R_t/R_p/R_v/R_{3z}/R_{3y}/R_{zJIS}/R_{sk}/R_{ku}/R_{sm}/R_{mr}$ $\mu\text{m}$	max. %	cut-off length mm	mm	
657113	$R_a$ 0.005 – 16.00 / 0.02 – 160.00	$\pm 0.60$ %	< $\pm 10$	< 6	0.25 / 0.80 / 2.50	140 x 55 x 47

## Accessories for art. no. 657113

- art. no. 657210 tracer, straight (standard)
- art. no. 657211 tracer, angled
- art. no. 657212 tracer, for  $\varnothing$  3 mm bore depth
- art. no. 657213 tracer, for  $\varnothing$  10 mm bore depth
- art. no. 657214  $R_a$  test block
- art. no. 657218 stand
- art. no. 657219 PC software for wireless data transfer

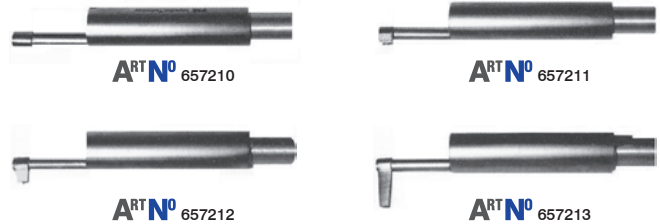

Example for a wireless transmission

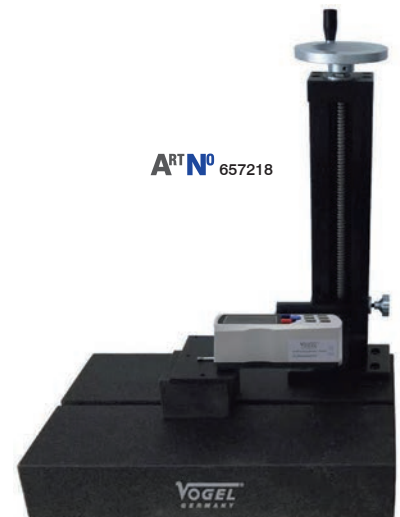

## Image/Video Borescope Console • IP54 with 3.5" TFT colour monitor, with connection for all our hoses

- top model for varied industry purposes, e.g. automotive-, machinery-, pipeline-, shipbuilding-, aircraft-, turbine-, wind power industry, and many more
- for quick, visual inspection and documentation, useful in hard to reach places
- with 3 adjustable LED's at the hose-end
- with USB 2.0, TV output (PAL), reset, mini-USB and micro SD slot
- spray water proof console, acc. to DIN 40050 / IEC 60529
- sturdy industry quality, housing with rubber cover, M6 thread insert
- 3.5 inch TFT colour monitor, monitor resolution 640 x 480 pixel
- photo taking (JPEG 1600 x 1200) and video recording (AVI)
- with zoom button (x2/x3/x4) and image freeze
- 180° frame rotation and mirror image
- 7 selectable languages, DE/EN/FR/ES/RU/JP/CN
- ON/OFF button, date/time function, power saving mode, battery status
- build-in flashlight (level-1/-2/-3)
- build-in rechargeable Li-ion battery
- incl. 4 GB memory SD card, USB power cable (USB/mini-USB), 240 V USB charger, AV cable, bracket with M6 thread, with operation manual



table stand with M6 thread



LED light (3 levels)

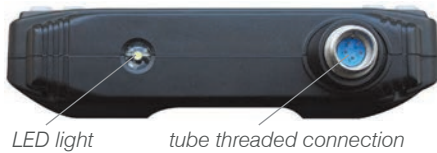

LED light

tube threaded connection



SD card slot

TV connection  
mini USB connection



memory card  
(4 GB)



extendable table stand

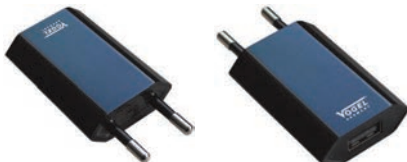

USB charger



Backside  
rear with rubberized housing protection



Backside  
rear without rubberized housing protection



USB charger cable



AV cable



Example: brake discs control



ART N<sup>o</sup>

620003



Photo (JPG)

1600 x 1200



Video (AVI)

640 x 480



145 x 95 x 37



# Photo/Video Endoscopes

## Image/Video Borescope Hoses • IP67 endoscope hoses with matching threaded connection suitable for our model console (art. no.: 620003)

- different hoses available
- oil-, water- and coolant proof, acc. to DIN 40050 / IEC 60529
- sturdy industry quality, flexible and semi-rigid design
- camera resolution 300.000 pixel
- perfect image recognition in the depth of field
- lenses with bright, white LED's
- 3 times adjustable LED light, console setting
- with operation manual

More hose types available on request



hose  
ø 3.70 mm or ø 4.50 mm,  
with 0° lens

above: hose ø 9.00 mm,  
with 0° and 90° lens



below: hose ø 3.70 mm,  
with 0° lens



hose ø 9.00 mm,  
with 0° and 90° lens



rubberized grip for secure grip,  
only at viewing direction 0° and 90°

ART NO	hose mm	field of view °	hose-Ø mm	quantity LED	hose type	
					flexible	semi rigid
620050	1000	0	3.70	6	✓	✗
620051	3000	0	3.70	6	✓	✗
620052	5000	0	3.70	6	✓	✗
620055	1000	0	4.50	6	✗	✓
620056	3000	0	4.50	6	✗	✓
620057	5000	0	4.50	6	✗	✓
620060	1000	0 / 90	9.00	4 / 2	✗	✓
620061	3000	0 / 90	9.00	4 / 2	✗	✓
620062	5000	0 / 90	9.00	4 / 2	✗	✓

# Other Digital Measuring Instruments

## Electr. Digital Moisture Meter

- for measurements of wood moisture, paper, building materials, etc.
- with 4 contact pins

- rugged, polyamide housing material
- large LCD display with clear reading
- On/Off button, data hold button
- autom. power off, battery indicator
- setting the upper limit of the moisture ratio
- storage temperature -10 °C ~ +60 °C, operation temperature 0 °C ~ +40 °C, rel. humidity < 70 % RH
- incl. 1x 9 V battery (type 6LR61, art. no.: 90006), with operation manual



<b>ART NO</b>	 wood		 max.	 mm
<b>641006</b>	5 % – 40 %	1.0 %	±1.0 % Rh+0.5	129 x 63 x 32

## Electr. Digital Moisture Meter

- for measurement of building materials, concrete, wood, etc.

- robust, ABS plastic housing
- large LCD display, 3 digits, with clear reading, digit height 15 mm
- On / Off key, data hold function, min / max key, measurement in digits
- depth of penetration about 20 – 40 mm
- low battery indication, backlight switchable
- storage temperature 0 °C ~ 50 °C, rel. Humidity < 80 % RH
- incl. 1x 9 V battery (type 6LR61, art.-no.: 90006), with operation manual









<b>ART NO</b>	 capacity device digits		 max.	 mm
<b>641009</b>	0 – 100	1	±1	180 x 45 x 35

## Electr. Digital Moisture Meter

- for measurements of wood moisture, paper, carton, building material, grain, etc.
- with insulating peel
- measurement via 2 external contact pins

- rugged, polyamide housing material
- large LCD display with clear reading
- On/Off button, data hold button, button for wood density selection
- button for selection of moisture measurement / temperature measurement (in °C or °F)
- battery indicator, with backlight
- setting the upper limit of moisture ratio, rel. humidity < 70 % RH
- storage temperature -10 °C ~ +60 °C, operation temperature -10 °C ~ +40 °C
- incl. 4x 1.5 V battery (type AA, art. no.: 90003), with operation manual



<b>ART NO</b>	 wood		 max.	 temperature		 max.	 mm
<b>641008</b>	2 % – 70 %	0.5 %	±1.0 % Rh+0.5	-10 °C – 60 °C	1 °C / 2 °F	±2 °C / ±4 °F	174 x 38 x 73

# Other Digital Measuring Instruments

## Electr. Digital Sound Level Meter

- for sound and noise measurements acc. to the international directives whether in industry, craft, or housekeeping
- useful device for air-conditioning, aviation industry, environmental technology
- with self-calibration

- rugged, polyamide housing material
- On/Off button, data memory for 4700 measurements, slow-/fast-button, clock- and calendar indicator
- with tripod mounting screw on the rear side, autom. power off
- large LCD display, 4-digit, with clear reading, battery indicator
- frequency range 31.5 Hz ~ 8.5 KHz, A/C frequency weighting select switch, AC/DC out put
- bar graph indicator with 50 dB scale, 1 dB step, with pre-select of min/max.-value
- microphone 1/2 inch, electret condenser-microphone, with detachable foam ball for outside measuring
- storage temperature -20 °C ~ +70 °C, operation temperature 0 °C ~ +45 °C, DC 6 V input port, AC analog output port
- incl. 4x 1.5 V battery (type AA, art. no.: 90003), USB data cable, software, with operation manual



### Option

- charging by power supply possible (only when using rechargeable batteries)



ART No	level range: dBA / dBC	dB	max. dB	linearity range dB	mm	CC
641106	40 - 80 / 50 - 100 / 60 - 110 / 80 - 130	0.10	±1.50	50	220 x 80 x 35	inclusive
641107	40 - 80 / 50 - 100 / 60 - 110 / 80 - 130	0.10	±1.50	50	220 x 80 x 35	—

## Electr. Digital Luxmeter

- utilising a silicon photo diode with filter behind a large diffusor that is connected to the device by cable ensures that the light intensity can be read in all positions without restriction

- rugged, polyamide housing material
- large LCD display, 3½ digit, with clear reading
- On/Off switch, data hold switch, 3-step measurement setting function
- max. reading value 1999, test rate 0.5 sec., temperature characteristic ±0.1 % / °C
- storage temperature -20 °C ~ +70 °C, operation temperature 0 °C ~ +45 °C
- incl. 1x 9 V battery (type 6LR61, art. no.: 90006), with operation manual



ART No	LUX	LUX	< 10.000 LUX	> 10.000 LUX	mm	CC	
640342	1 - 100.000	1	±4 %	±5 % ±10 Digits	±2 %	130 x 72 x 30	on request

## Electr. Digital Anemometer

- for many outdoor applications and for several industry purposes
- for to measure the wind speed in different units
- ideal device for heating- and ventilation technician, shipping industry, etc.
- with Beaufort scale display

- rugged, polyamide housing material
- with tripod mounting screw on the rear side
- large LCD display with clear reading and backlight
- wind speed unit selection: m/s; Ft/min; Knots; Km/h; Mph
- with max.-value and data hold button, average and current speed measuring, temperature reading in °C and °F, switchable
- storage temperature -20 °C ~ +70 °C, operation temperature -10 °C ~ +45 °C
- incl. 1x 9 V battery (type 6LR61, art. no.: 90006), with operation manual

- Art. no. 641205: without data output
- Art. no. 641204: without data output, with external impeller



ART No	wind speed m/s	speed m/s	temperature °C	wing speed	temperature °C	temperature °C	mm
641204	0.3 ~ 45	—	0.1	0.2°	±0.1 Digit	±2°	160 x 62 x 35
641205	0.3 ~ 30	—	0.1	0.2°	±0.1 Digit	±2°	165 x 85 x 38

# Other Digital Measuring Instruments

## Testboy • Magnet Field Detector, non contact

- with LED lamp, non contact
- easy and quick contact-free detection of magnetic-fields
- all permanent and synthetic magnetic fields are indicated by the tip lighting up
- the built-in magnet-field sensor allows a reliable check proper function of hydraulic and pneumatic valves, relays and contactors
- rugged ABS-plastic housing, with clip
- safe and contactless testing, works at a distance of 4 mm
- optical red LED display, with built-in permanent magnet for a quick self test
- incl. 2x 1.5 V battery (type AAA, art.-no.: 90002), with operation manual



<b>ART N°</b>		
640376	all magnetic fields	length x ø 160 x 25

## Testboy • Brake Fluid Tester, DOT 3, DOT 4, DOT 5.1 • IP44

- fast and accurate check on the water content in the brake fluid
- thanks to various measuring ranges, user-friendly operation and compact design, the device is ideal for use in garages and motorcycle workshops
- check brake fluids DOT 3, DOT 4, DOT 5.1
- acid- and alkaline housing, with clip
- visual indicating via 3 LED's
- measuring point illumination
- incl. 2x 1.5 V battery (type AAA, art.-no. 90002), with operation manual



<b>ART N°</b>		
640372	DOT 3 / DOT 4 / DOT 5.1	L x ø 152 x 23.5

## Electr. Digital Tire Pressure Gauge

- for quick and independent measuring of the tire pressure
- sturdy ABS plastic housing
- large LCD display with clear reading, digit height 9.5 mm
- LCD display with backlight
- lighted valve tip
- On/Off button, autom. shutdown
- units in PSI, Bar, Kg/cm<sup>2</sup>, Kpa, switchable
- reading 0.1 PSI; 0.01 Bar; 0.01 Kg/cm<sup>2</sup>; 1 Kpa
- incl. 1x 3 V battery (type CR2032, art.-no.: 90112), with operation manual



<b>ART N°</b>	for cars				
214460	✓	PSI	Bar / Kg/cm <sup>2</sup>	Kpa	max. %
		0 – 100	0 – 7 / 0 – 7	0 – 700	1 %





# Voltage Tester

## Testboy • Voltage Detector • IP44

- non-contact type, rapid detection of live conductors to e.g. cable connections, cable reels, sockets, electrical outlets, switches, etc.
- particularly well-suited for professional use and as well for hobby

- sturdy ABS-plastic housing, with clip, dustproof and spray water resistant
- contactless and safe testing, works at a distance of 4 mm
- with acoustical signal and built-in LED lamp on top, measuring range 12 V – 1000 V
- overload category CAT III 1000 V
- capacitive process
- incl. 2x 1.5 V battery (type AAA, art. no.: 90002), with operation manual





<b>ART N°</b>	 V AC	 L x ø
640357	12 – 1000	160 x 25

## Testboy • Two Pole Voltage Tester • IP65

- the professional appearance is underlined by the mix of materials used in the plastic housing and the rubber handle
- display window made of break proof plastic, scratch resistant

- sturdy ABS-plastic housing, water- and coolant proof acc. to DIN 40050 / IEC 60529
- single pole phase testing, two pole phase sequence testing, autom. load for FI/RCD test
- autom. measurement range, autom. resistance: Is ~ 30 mA ED(DT) = 30 sec.
- operation panel: finger tip contact, continuity test 0 – 500 kOhm, with acoustical signal
- incl. 2x 1.5 V battery (type AAA, art.-no.: 90002), with operation manual





<b>ART N°</b>	 V AC / DC	phase indicating	overload category	 L x B x H
640332	6 – 1000 AC / DC	> 100 V AC	CAT IV 1000 V	238 x 70 x 30

## Testboy • Two Pole Voltage Tester • IP44

- with 8 LED's, user-friendly design
- for measuring AC / DC, two practical functions in a single device
- the instrument has met with the approval for many customers working in the electrical- and tools branch

- sturdy ABS-plastic housing with rubber handle, dustproof and spray water resistant
- protected against voltage loads from 6 up to 400 V AC / DC
- DC and AC voltage tests with polarity indication can be performed safely
- power supply by test object
- overload category CAT III 1000 V
- with operation manual





<b>ART N°</b>	 V AC / DC	display	 L x B x H
640356	6 – 400	8 LED's	120 x 60 x 30

## Testboy • Car Tester, Voltage Tester for 3 – 48 V • IP40

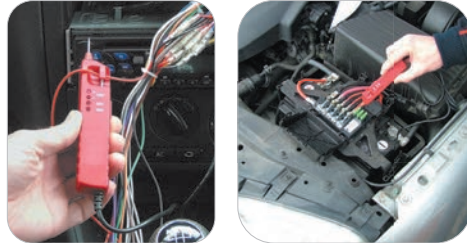
- with integrated piercing probe  
perfect instrument for fault diagnostics in cars, trucks, etc.
- rugged ABS plastic housing, dust proof
- LED's with indicating 12 V / 24 V / 48 V
- power supply via test object
- protection class III, IEC/EN 61010-1
- with operation manual





<b>ART N°</b>	 DC	 mm
640366	3 – 48 V	145 x 25 x 16

## Testboy • Electr. Digital Miniature Current Clamp • IP44

- the manual/automatic test range selector enables versatile and reliable testing  
use in the service sector, in industry or in the installation  
whether you want to measure a direct current as shown in the picture to check that a battery's load current will be sufficient, or the load is pulling too much and causing leakage
- the included readiness-bag keeps the device and its attachments safe, even in harsh areas or on the road
- protected housing made of sturdy ABS-plastic, dustproof and spray water resistant
- LCD display with clear reading
- voltage up to 600 V, current AC/DC up to 600 A
- overload category CAT III, 600 V, conductivity with acoustical signal, resistance 0 – 60 Ω
- with diode test, with testing lead set
- incl. 3x 1.5 V battery (type AAA, art.-no.: 90002)
- incl. operation manual



<b>ART N°</b>	 DC	 mm
640364	- 600 V AC/DC	- 600 A AC/DC
		208 x 75 x 35

# Multimeter

## Testboy • Electr. Digital Multimeter • IP44

• with LED lamp and with non-contact voltage tester  
very useful instrument, especially in the field of electrical engineering

- housing is made of tough, damage-resistant ABS-plastic, dustproof and spray water resistant
- large LCD display for clear reading
- current DC and AC up to 4 A
- diode test, transistor test function, conductivity test, with acoustical signal
- incl. 1x measuring lines
- incl. 2x 1.5 V battery (typ AAA, art. no.: 90002), with operation manual





<b>ART NO</b>	 AC/DC	overload protection	resistance	
640382	0 – 400 V	CAT III / 300 V	2 MΩ	140 x 70 x 35

## Electr. Digital Multimeter • IP44

• with solar charger on top of instrument  
very useful instrument, especially in the field of electrical engineering

- housing is made of tough, damage-resistant ABS-plastic, dustproof and spray water resistant
- large LCD display clear reading, digit height 19 mm
- current DC and AC up to 20 A
- incl. thermo probe for temperature measurements
- diode test, transistor test function, conductivity test, with acoustical signal
- with battery test function
- with frequency function
- with decimal digits change
- incl. 2x measuring lines
- incl. rechargeable accu and charger cable, with operation manual



<b>ART NO</b>	 AC	 DC	overload category	resistance	
640384	0 – 750 V	0 – 1000 V	CAT III / 600 V CAT IV / 1000 V	60 MΩ	167 x 90 x 50

## IP-Protection types overview acc. to EN 60529 (IP • International Protection)

### 1. Index

Degree of protection against foreign objects/particles and dust

- IP 4.. Protection against penetration of solid foreign objects von  $\geq 1$  mm.
- IP 5.. Protection against harmful dust deposits (dust protected).
- IP 6.. Protection against penetration of dust (dust-proof).

### 2. Index

Degree of protection against water

- IP ..0 no protection
- IP ..2 Protection against dripping water up to 15° tilt housing.
- IP ..4 Protection against water spray from any direction.
- IP ..5 Protection against water jets from any direction.
- IP ..6 Protection against powerful water jets from any direction.
- IP ..7 Protection against temporary immersion in water.
- IP ..8 Protected from ingress of water during immersion for indefinite period.

## Tolerance limits acc. to EC-Measuring Directive 2004/22

Pocket Tapes / Steel Rules

Length	m	1	2	3	4	5	8	10
Tolerance class I	mm	±0.30	±0.40	±0.50	±0.60	±0.70	±1.00	±1.20
Tolerance class II	mm	±0.70	±0.90	±1.10	±1.30	±1.50	±2.10	±2.50

Folding Rules

Length	m	1	2	3
Tolerance class II	mm	±1.00	±1.20	±1.40
Tolerance class III	mm	±1.80	±2.20	±2.60

## Thickness tolerances for feeler gauges and feeler gauge rolls

nominal thickness mm	0.000 – 0.024	0.025 – 0.039	0.040 – 0.062	0.063 – 0.124	0.125 – 0.159	0.160 – 0.199	0.200 – 0.249	0.250 – 0.314	0.315 – 0.389	0.400 – 0.499	0.500 – 0.629	0.630 – 0.799	0.800 – 0.999	1.000 – 1.249	
Tolerance T2	μm	±2.00	±3.00	±4.00	±5.00	±6.00	±7.00	±8.00	±9.00	±11.00	±12.00	±14.00	±17.00	±19.00	±24.00
Tolerance T3	μm	±1.50	±2.00	±3.00	±4.00	±5.00	±5.00	±6.00	±7.00	±8.00	±9.00	±10.00	±12.00	±13.00	±17.00

## Measuring categories CAT I up to CAT IV

- CAT I:** approved for measurements on circuits that are not directly connected to the power grid. (e.g. specially protected devices)
- CAT II:** approved for measurements on circuits which are electrically connected directly to the low voltage grid. (e.g. household appliances)
- CAT III:** approved for measurements in building installation (e.g. as distribution, wiring, sockets, switches)
- CAT IV:** approved for measurements at the source of low-voltage installations (e.g. as meters, mains terminals, primary overcurrent protection devices)

Any questions?  
We are pleased to advise!

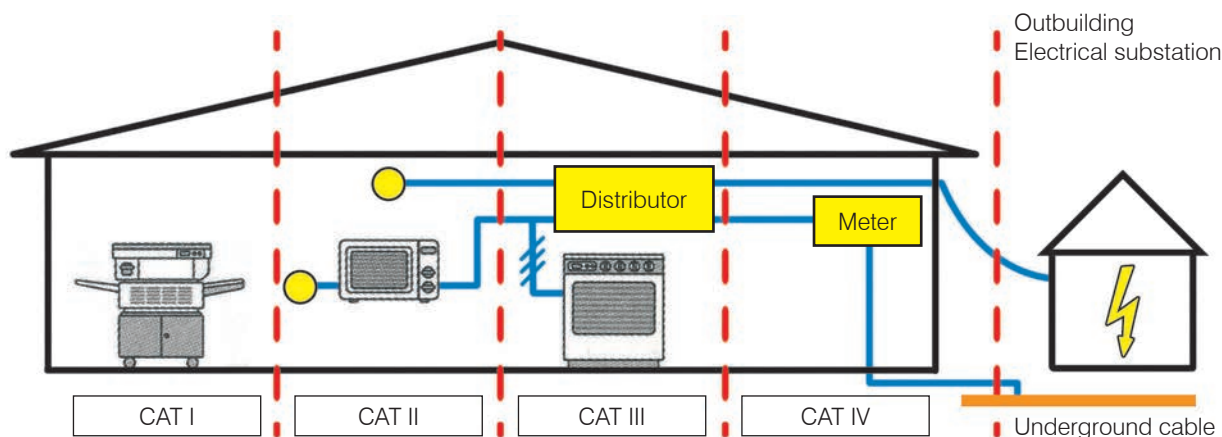



# Scales

## Kern • Electr. Digital Compact Scales

### • entry-level model in the low cost range, with weigh-in function

- rugged plastic housing, with large LCD unit, digit height 15 mm
- easy operation by two buttons
- connector for charger
- weigh-in function, by pressing the TARE-button switches over to "0", simplifies mixing
- automatic auto-off after 3 min. without change of load to preserve the battery
- incl. 2x 1.5 V battery (type AA, art. no.: 90003), with operation manual

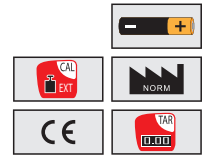

### Option

- charger 230 V/AC (art. no.: 273998)

ART N°	max. kg	g	weighing plate-ø mm	
273003	0.50	0.10	150	170 x 240 x 39
273004	0.20	0.01	105	170 x 240 x 39
273006	2.20	1.00	150	170 x 240 x 39
273008	6.00	0.10	150	170 x 240 x 39

## Kern • Electr. Digital Precision Scales • IP65 / IP67

- IP65: Dust and jet water proof acc. to DIN 40050 / IEC 60529
- IP67: Water and oil tight (at times) acc. to DIN 40050 / IEC 60529

- rugged metal housing, weighing plate made from stainless steel
- large LCD display, digit height 20 mm
- easy 3-/4-button operation, self-explaining
- operation by battery or main supply, switchable
- automatic power-Off after 3 min. without change of load to preserve the battery
- freely programmable weighing units
- adjusting program (CAL)
- incl. charger 230 V/AC and dust cover
- incl. operation manual



ART N°	max. kg	g	reproducibility g	linearity ± g	weighing plate mm		
273320	0.5	0.1	0.1	0.2	120 x 150	170 x 150 x 40	on request
273321	5	1	1	2	120 x 150	170 x 150 x 40	on request
273322	5   7.5	0.5   1	0.5   1	1.5   3	252 x 200	285 x 255 x 90	on request
273323	8   15	1   2	1   2	3   6	252 x 200	285 x 255 x 90	on request
273324	16   30	2   5	2   5	6   15	252 x 200	285 x 255 x 90	on request

## Kern • Electr. Digital Compact Scales

- industry quality design, with robust tuning fork weighing system
- with data output RS 232

- rugged metal housing, weighing plate made from stainless steel
- large LCD display, digit height 16,5 mm
- automatic power-Off after 3 min., without change of load to preserve the battery
- PRE-TARE button for manual subtraction of a known container weight
- power supply with 9 V block battery (not included)
- with animal weighing program, strong vibrations are filtered out
- incl. dust cover and operation manual
- Internal automatic adjustment, Automatic adjustment CAL for setting the accuracy using a test weight
- Capacity display and autom. reference optimization



### Options

- RS-232 / Bluetooth® adapter for connecting Bluetooth® capable devices, art.-no.: 273063-1
- RS-232 / WLAN adapter for wireless connection to network and WLAN-compatible devices, art.-no.: 273063-2

ART N°	max. kg	g	verification value [e] g	minimum weight [min] g	linearity ± g	weighing plate mm		
273063	0.62	0.001	—	—	0.004	∅ 140	202 x 293 x 266	on request
273064	3.2	0.01	—	—	0.02	190 x 190	195 x 290 x 90	on request
273065	12	0.1	—	—	0.2	190 x 190	195 x 290 x 90	on request
273067	0.62	0.001	0.01	0.02	0.004	∅ 140	202 x 293 x 266	on request
273068	3.2	0.01	0.1	0.5	0.02	190 x 190	195 x 290 x 90	on request
273069	12	0.1	1	5	0.2	190 x 190	195 x 290 x 90	on request

## Kern • Electr. Digital Parcel Platform Scale

### • cheap parcel and allround scales, for despatch weighing

- rugged metal housing, weighing plate made from stainless steel
- with wall mounting for electr. unit
- large LCD display, digit height 25 mm
- weighing units in kg or lb
- display unit placed anywhere by flexible spiral cable (approx. 2 m)
- easy 4-button operation, self-explaining
- automatic power-Off after 3 min., without change of load to preserve the battery, permissible temperature +10 °C ~ +35 °C
- with animal weighing program
- weigh-in function, by pressing TARE-button switches over to "0"
- adjusting programme (CAL) means for adjusting the precision test weights, (not included)
- mains or battery operation possible  
(6x 1.5 V battery, type AA, art. no.: 90003, batteries are not included)
- incl. charger 230 V/AC, with operation manual

### Option

- stand, art. no.: 273558 (stand only)



art. no.: 273558,  
stand only



ART NO	max. kg	g	readout g	linearity ± g	weighing plate mm	mm LCD	CC
273302	35	10	10	20	310 x 305 x 55	210 x 110 x 45	on request
273303	60	20	20	40	310 x 305 x 55	210 x 110 x 45	on request
273305	150	50	50	100	310 x 305 x 55	210 x 110 x 45	on request
273308	300	100	100	200	310 x 305 x 55	210 x 110 x 45	on request

## Kern • Electr. Digital Parcel Platform Scale • IP65

- multimodel platform scale
- for industrial purpose, with piece-counting, reference quantities selectable
- dual range scale, automatically switches to the next higher weighing range
- dust- and splash water proof acc. to DIN 40050 / IEC 60529

- industry scale with rugged plastic housing, stainless steel weighing plate
- with large LCD display, with backlight, digit height 25 mm
- freely programmable weighing units, e.g. in yarn length g/m, in paper weight g/m<sup>2</sup>, etc.
- display unit (IP 65) placed anywhere by flexible spiral cable (approx. 1.4 m)
- easy 5-button operation, self-explaining, with animal weighing program
- with data output RS 232 C, for data-printer or computer connection
- mains or battery operation possible  
(1x 9 V battery, type 6LR61, art.-no.: 90006, batteries are not included)
- adjusting program (CAL), piece-counting (PCS), net-total weighing (REZ)
- automatic power-Off after 3 min., permissible temperature +5 °C ~ +35 °C
- incl. charger 230 V/AC, dust cover, with operation manual

### Option

- stand, art.-no.: 273550



art.-no.: 273550, stand only

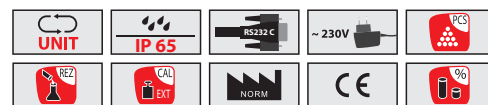

ART NO	max. kg	g	reproducibility g	linearity ± g	weighing plate mm	mm LCD unit	CC
273054	15 / 35	5 / 10	5 / 10	15 / 30	318 x 308 x 75	225 x 110 x 45	on request
273057	30 / 60	10 / 20	10 / 20	30 / 60	318 x 308 x 75	225 x 110 x 45	on request
273059	60 / 150	20 / 50	20 / 50	60 / 150	318 x 308 x 75	225 x 110 x 45	on request
273061	150 / 300	50 / 100	50 / 100	150 / 300	522 x 403 x 90	225 x 110 x 45	on request

# Scales and Dynamometers

## Kern • Electr. Digital Industrial Counting Scales

- verifiable
- entry level model into the professional-counting

- industry scale with rugged metal housing, stainless steel weighing plate
- with 3 large LCD displays, with backlight, digit height 18 mm
- verifiable weight display, reference weight, total number of pieces
- programmable via keypad: known reference weight / reference quantity
- accurate counting: the autom. reference optimization gradually improves the average value of the piece weighing
- cumulative counter memory: summing up of the same counting parts and total pieces and total weight, counting resolution: 30000 points
- acoustic beep „Fill-to-target“: target quantity and target weight programmable
- weigh-in function, by pressing the TARE-button switches over to "0", simplifies mixing
- permissible temperature -10 °C ~ +40 °C
- standard with charger, internal (please mention the country location of use) and operation manual



### Option

- **verification** or DAKkS calibration certificate by extra charge (with **verification**: location of use with post code required - subsequently not possible)



- high mobility, thanks to battery operation
- with recessed grips

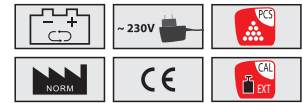

ART NO	max. kg	g	verification value [e] g	minimum weight [min] g	minimum weight g/pc.	weighing plate mm	mm	CC
273022	3	1	1	20	0.1	300 x 225	300 x 330 x 110	on request
273024	15	5	5	100	0.5	300 x 225	300 x 330 x 110	on request
273025	30	10	10	200	1	300 x 225	300 x 330 x 110	on request

## Electr. Digital Force Gauges

- robust push/pull force gauge, for simple measurements

- measurement accuracy is from max. 0.5 % of capacity, data sampling rate 1000 Hz
- large LCD display with backlight
- overload protection 2 % of full scale
- reversible display with automatic direction detection
- with peak hold function, real time or peak hold mode to observe
- automatic power-Off
- incl. standard attachments and extension rod (90 mm long)
- incl. 1x 1.5 V battery (type AAA, art.-no.: 90002), charger and operation manual



standard attachments and extension rod 90 mm



ART NO	N max.	N	measuring units	mm	CC
270353	100	0.05	N / kgf / lbf / oz	195 x 84 x 35	on request
270354	250	0.10	N / kgf / lbf / oz	195 x 84 x 35	on request
270355	500	0.20	N / kgf / lbf / oz	195 x 84 x 35	on request
270356	1000	0.50	N / kgf / lbf / oz	195 x 84 x 35	on request

## Electr. Digital Hanging Scale

- for mobile use
- for weighing by hand or for hanging up on an angle bracket
- sturdy ABS-plastic housing with a stainless steel hook
- large LCD display with digit height:
  - art.-no. 273087 about 13 mm / art.-no. 273082 about 11 mm
- with data hold button, display can be "frozen" for approx. 5 sec., makes reading easier
- On/Off-button, TARE-button: attach an empty vessel/container and place the display to zero
- weighing units: kg, lb and N (Newton)
- automatic power-Off
- permissible temperature +5 °C ~ +35 °C
- 
- **art.-no. 273087:** - only suitable as luggage scale, **not calibratable**
  - incl. 2x 1.5 V battery (type AAA, art.-no.: 90002)
  - not calibratable (simple household scale)
- **art.-no. 273082:** - with built-in measuring tape (100 cm)
  - incl. 1x 9 V battery (type 6LR61, art.-no.: 90006), and operation manual

### Option

- **art.-no. 273082:** DAkkS calibration certificate by extra charge (afterwards not possible)

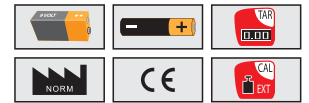

ART N°	max. kg	g	mm	CC
273082 (Kern)	50	100	90 x 30 x 175	on request
273087 (Vogel Germany)	30	10	95 x 23 x 195	—

## Kern • Electr. Digital Crane Scale

- TÜV approved crane scales acc. to the standards of EN 13155 (loose load receptor) and EN 61010-1 (electr. safety)
- **art.-no. 273100 – 273103** prof. device for rough application (industry quality)
- **art.-no. 273110 – 273111** compact crane scale (for standard purpose)
- **art.-no. 273100 – 273103** self-luminous LED display, digit height 30 mm
- **art.-no. 273110 – 273111** LCD display with backlight, digit height 23 mm
- **art.-no. 273100 – 273103** incl. remote control, up to 20 m working range
- **art.-no. 273110 – 273111** incl. infrared-remote control, up to 2.5 m working range
- with data-hold button, to hold the display value
- **art.-no. 273100 – 273103** with adaption to unstable conditions
- hook with saftey lock, made from forged steel, chromed, turnable
- standard with internal battery, incl. charge 230 V/AC
- remote control incl. 2x 1.5 V battery (type AAA, art.-no.: 90002)
- adjusting programme (CAL), weigh-in function, by pressing TARE-button switches over to "0"
- accuracy 0.2 % from [max], permissible temperature 0 °C ~ +40 °C
- incl. operation manual

### Option

- DAkkS calibration certificate by extra charge (afterwards not possible)

ART N° 273110 - 273111      ART N° 273100 - 273103

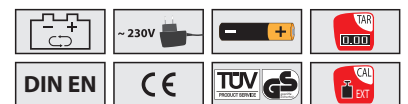
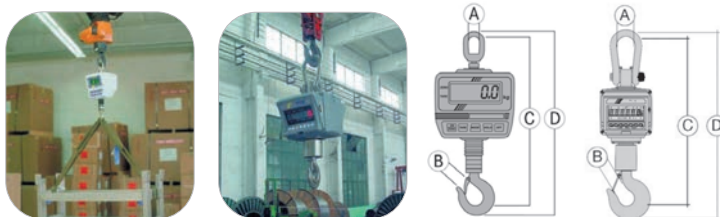

ART N°	max. kg	g	A	B	C	D	mm	CC
273100	1000	100	80	40	540	610	270 x 175 x 200	on request
273101	3000	500	75	50	540	610	270 x 175 x 200	on request
273102	5000	500	75	50	650	730	300 x 190 x 230	on request
273103	10000	1000	100	60	750	840	300 x 190 x 230	on request
273110	300	100	26	25	358	390	163 x 120 x 159	on request
273111	600	200	26	25	358	390	163 x 120 x 159	on request



# Dynamometers

## Kern • Electr. Digital Hanging Scale • also with IP65

- with stainless steel snap link and S-hook made from stainless steel
- art.-no. 273083 – 273086 with sturdy ABS plastic housing
- art.-no. 273095 – 273097 with sturdy stainless steel housing, in IP65 design
- art.-no. 273083 – 273086 large LCD display, digit height 12 mm
- art.-no. 273095 – 273097 large LCD display, at front and rear side, digit height 12 mm
- with data hold button, display can be "frozen" for some seconds, adjusting programme (CAL)
- TARE-button: attach an empty vessel/container and place the display to zero
- automatic power-Off after 3 min., without change of load to preserve the battery
- art.-no. 273083 – 273086 incl. 3x 1.5 V battery (type AA, art.-no.: 90003)
- art.-no. 273095 – 273097 incl. 2x 1.5 V battery (type AA, art.-no.: 90003), incl. operation manual



ART N° 273094 – 273097

ART N° 273083 – 273086



ART N°	IP65 water- and coolant proof	max. kg	g	mm	total height incl. hooks mm	CC
273083	X	20	10	80 x 45 x 150	290	on request
273084	X	50	100	80 x 45 x 150	290	on request
273085	X	100	200	80 x 45 x 150	290	on request
273086	X	200	500	80 x 45 x 150	290	on request
273095	✓	50	100	95 x 55 x 175	315	on request
273096	✓	100	200	95 x 55 x 175	315	on request
273097	✓	200	500	95 x 55 x 175	315	on request

## Test Weights



















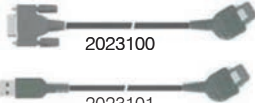



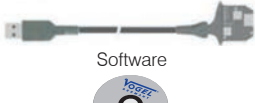

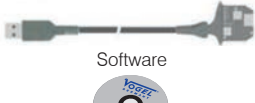



- for checking of measurements and scales
- available as single weights or in sets
- M1-Quality Class, stainless steel made, finely turned
- DAkkS calibration certificate (with extra charge)
- in a plastic case with soft insert (wooden case on request)

Other weights or set-components are available on request!



ART N°	kg	max. ± mg	CC	ART N°	kg	CC
Quality Class M1				Set-Components Quality Class M1		
273266	0.10	5	on request	273282	0.001 – 0.50	on request
273268	0.50	25	on request	273283	0.001 – 1.00	on request
273269	1.00	50	on request	273285	0.001 – 5.00	on request
273270	2.00	100	on request	—	—	—
273271	5.00	250	on request	—	—	—

# Data Processing

	ART N°	article description		ART N°	article description
 <p>compatible with</p> 	2040101	WiFi	 <p>compatible with</p> 	3420195	<p>USB - Mini-USB interface box with data key and with foot switch port</p> <p>optional, additional available: foot switch (art.-no.: 209011)</p>
 <p>compatible with</p> 	2040102	WiFi Mini-USB	 <p>compatible with</p> 	230139	<p>USB - Mini-USB interface box with data key and with foot switch port</p> <p>optional, additional available: foot switch (art.-no.: 209011)</p>
 <p>2023100</p> <p>2023101</p> <p>Software</p> 	2023100	PROXIMITY - RS232 Software	 <p>compatible with</p> 	209001	Interface USB - Mini-USB, 0.01 mm / 0.001 mm, with data key
 <p>Software</p> 	2023101	PROXIMITY - USB Software		209010	foot switch made of metal, with cinch plug 2.5 mm
 <p>Software</p> 	2424101	POWER - USB, external power Software		209011	foot switch made of metal, with cinch plug 3.5 mm
	2020188	USB - RS232, adapter (optional suitable for 2323100)		2023105	wireless data transfer transmitter module for measuring devices with proximity interface
 <p>compatible with</p> 	2420192	USB - Mini-USB (with data key) optional, additional available: foot switch (art. no. 209011)		2023104	wireless data transfer USB receiver (up to 15 m distance)
 <p>compatible with</p> 	2420194	USB-PC - Duo-Data output interface box with data key and with foot switch port (connectivity also for Mitutoyo Digimatic measuring devices) optional, additional available: foot switch (art.-no.: 209011)		2023106	wireless data transfer USB receiver Bluetooth®
				2023106S	wireless data transfer USB receiver Bluetooth®
				209000	Bluetooth® transmitter
				209009	Bluetooth® transmitter Mini-USB

Our certified QM-System is constantly controlled and improved by internal and external Audits of **TÜV Rheinland**.



## Calibration certificates for our products on request, please!



### Workshop Calibration Certificate in german or english language, acc. to DIN/ISO etc.

**Scope:** Calibration certificate indicating the deviation and limits of normal and with the test curve(s) for the measured according to the criteria of standards, confirmation of their performance. Confirmation of traceability to national normal, indicating an identification number.

**Validity:** Individually for each single instrument/device. Period of validity in accordance with your quality management manual (usually 12 month)

**Price:** See our price list, prices valid only for initial delivery from the factory, price for re-calibration on request, please.



### Calibration test report by an accredited testing laboratory

**Scope:** As mentioned above, calibration test report as mentioned above, but accredited by testing laboratory.

**Validity:** Individually for each single instrumen/device. Period of validity in accordance with your quality management manual (usually 12 month)

**Price:** see price list, prices valid only for initial delivery from the factory, price for re-calibration on request, please.



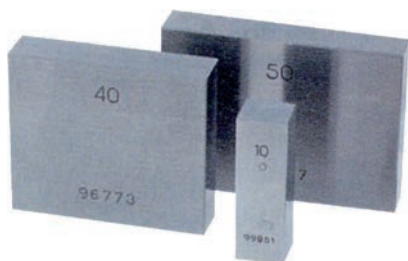

# Calibration

## Parallel Gauge Blocks made of steel and ceramic



example

 max. mm		 only steel
100	3594001	3594001-DKD
200	3594002	3594002-DKD
500	3594003	3594003-DKD
1000	3594004	3594004-DKD

## Digital Luxmeter



example



6494340

## Sound Level Meter



example



6494101



6494101-DKD

## Electr. Digital Protractors



example



3294010

# Calibration

## Coating Thickness Gauges



example



4894200

## Layer Thickness Calibration Films



example



4894201

## Digital Rebound Hardness Tester



example



6594600

## Surface Roughness Tester



example



Calibration Test Block

6594100



Surface Roughness Tester

6594111

## Hand Tachometer



example



2794110



Dakks

2794110-DKD